



Uwe Hagenbach & Bernhard Grill



Motoryoke

MB S60

Software version 4.51

Functional description MB S60

Fabrication and marketing
Licht-Technik Vertriebs GmbH
Hagenbach & Grill

Osterwaldstr. 9-10 80805 München
Tel. 089-360528-0 Fax 089-360528-30

Last updated on: 07/02/18 Rev.: 1.01

Caution! Operate the device only after having read and **understood** operating instructions!

Table of content

The Licht-Technik Motoryoke.....	4
Identification.....	5
Safety- and operating instructions.....	6
The DMX-standard in lighting.....	9
Cabling.....	10
Getting started.....	11
PAN – axis moving range.....	12
User interface.....	16
Display lighting ON/OFF.....	16
DMX channels motoryoke.....	17
P01 DMX-Address motoryoke.....	18
P02 Lamp rotation ON/OFF.....	19
P03 Motorised barndoor ON/OFF.....	20
P05 PAN-axis middle position.....	21
P06 TILT-axis 0-position.....	22
P07 Barndoor rotation middle position.....	23
P11 PAN-axis moving range.....	24
P12 TILT-down (negative) moving range.....	25
P13 TILT-up (positive) moving range.....	26
P14 Lamp rotation 0%-value adjustment.....	27
P15 Lamp rotation 100%-value adjustment.....	28
P16 Barndoor 1 closed position.....	29
P18 Barndoor 2 closed position.....	30
P20 Barndoor 3 closed position.....	31
P22 Barndoor 4 closed position.....	32
P23 Barndoor 1..4 moving range.....	33
P24 All barndoors closed position adjustment	34
P25 Barndoor rotation moving range.....	35
P27 Speed PAN/TILT setup.....	36
P28 Barndoor automove function ON/OFF.....	37
P30 Displaying the DMX-value.....	38
P32 Selecting the user language.....	39
P36 Interchanging PAN moving direction.....	40
P37 Interchanging TILT moving direction.....	41
P38 Interchanging lamp rotation moving direction.....	42
P39 Interchanging barndoor rotation moving direction.....	43
P40 Unit number Netspider.....	44
Technical data.....	45
Readjustment of motoryoke axis.....	46
Factory presettings.....	47
Maintenance.....	48
Error messages.....	50
Malfunctions.....	51
Warranty.....	52
Further information.....	52
EC Declaration of Conformity.....	53

The Licht-Technik Motoryoke

The motorized yoke of Licht-Technik is a **versatile, precise** and **powerful** device for headlight positioning.

Since 1991 the company Licht-Technik designs motoryokes for film, TV and theatre houses. We only use the best components of the world-wide leading companies. The **aluminium** housings are characterised by high stability, high quality and low dead weight. The devices are manufactured on own **CNC** controlled machines and can guarantee a continuously **high quality standard**. Noise is optimised sequentially and provides thereby for extremely quiet positioning of the headlights. We manufacture the Motoryokes in co-operation with our customers for the desired sizes.

The control is made by the **DMX-512 USITT**-interface. The rough and fine positioning and the speed for each main-axis (PAN/TILT) can be controlled. As an option a focus unit and/or a motorized barndoor can be controlled by DMX.

The Motoryoke can be offered with the following **options**:

Motorised barndoors:

A motorized 4-wing-barndoor can be controlled by the yoke. The positioning takes place in 256 steps (1 DMX-channel for every barndoor and 1 channel for rotation). The rotation can turn 182 degrees. The barndoors opens 125 Grad at maximum. The motorized barndoor has an intelligent controlling (automove function) so that no crash will occur when 2 or more wings will be closed or opened.

The built in **32-Bit Processor** provides a high throughput of the computer, quick positioning and uncomplicated handling. Even when triggering several motoryokes the precise control system provides a high synchrony of the movement.

Because of the absolute value device, the motoryoke does not perform any **initialisation runs** after power up.

The lighted **LCD display** (the light can be switched off) leads the user in plain text instructions through the various programming steps. The instructions are available either in english or german language.

The motoryoke has a mechanical and electronical **torque delimitation** on the PAN and TILT axle. The mechanical torque limitation is realised with a friction **clutch** and prevents a personal injury of people working on the yoke. Furthermore the drives and gearboxes will not be damaged when moving the yoke in case of power off.

The **electronical torque delimitation** switches off the motors in case of blocking (e.g. blocking because of moving onto a wall or decoration). The display shows an appropriate error message.

The **controlling** of the two main axes (PAN and TILT) is done with 2 DMX-channels per axle. With only one channel (8-Bit) a resolution of 256 steps could be realised. With two channels (16-Bit) a resolution of **65536 steps** is possible. The first channels of each axle represents the rough position information (at 360° range of rotation about 1.4 degrees per step). The second channel represents the fine position information. The speed of the motoryoke is determined with one channel (PAN and TILT together) or with two channels (PAN and TILT separated).

Identification

Motoryokes are **identified** by a number on the identification plate as follows:

MB – XX / Y ZZZ

MB	=	Motoryoke. On every motoryoke identification plate.
XX	=	ST: Type: Studio yoke R: Type: tube yoke SH: Type: Show yoke S60: Type: For ARRI S60
Y	=	A: Small size B: Medium size C: Big size
ZZZ	=	3 digit number e.g. 008, 013 etc. Determines the geometry and size (e.g. length of the arms) Numbering not sorted by anything.

Motorized barndoors are **identified** by a number on the identification plate as follows:

MT – XXX – YY – V?

MT	=	Motortor (=motorized barndoor). On every barndoor identification plate.
XXX	=	diameter Available sizes are: 200,250,300,350,430,500
YY	=	Optional version number possible versions: 03
V?	=	Optional version number possible versions: V2

Focus drives are **identified** by a number on the identification plate as follows:

MB-F-XX-V?

MB	=	Motorbügel (=Motoryoke)
F	=	Focus
XX	=	Version number. Possible versions: 12,13,15
V?	=	Optional version number. Possible versions: 1,2,3

Safety- and operating instructions

The motoryokes are tested by the german trade association (*Berufsgenossenschaft*). The devices conform with BGV C 1 and **correspond** to the newest safety regulations.

Never exceed the maximal possible **load of the mounting point**. (Rigg etc.)

Make sure that the **maximum load** of the fastening spigot will not be exceeded.

Never exceed the **maximum load** of the motoryoke. It is written on the identification plate.

The Motoryoke must only be operated in the **operating position** provided for this purpose. Operating position is vertically hanging down, fastening spigot on the top.

Make sure that all fixtures of the yoke are **tightened**. Observe the torque of the screws or nuts.

Fast the headlight and all accessories like color changer, dimmer shutter and barndoor with **safety belts**. See picture:

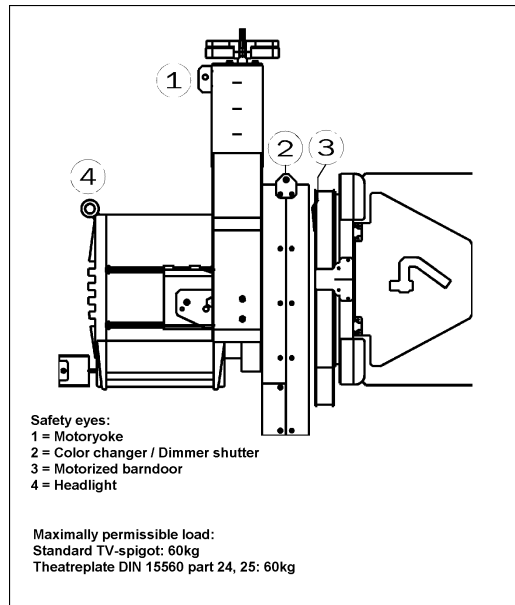

Make sure that the safety belts have the right diameter. For weights up to 60 kg a belt of 10mm diameter is necessary for the one way method and a belt of 6mm is necessary for the two way method.



One way safety belt

Two way safety belt

The user is **responsible** for the correct use of safety parts!

Make sure that all parts which are mounted on the headlight are right **tightened**.

Lever forces must not have an effect on the Motoryoke. This means that the installed motoryoke must not be **shifted** or **bended**! It is also forbidden when fastening spigot is opened.

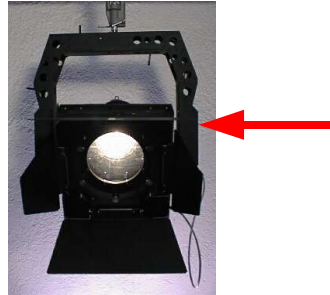
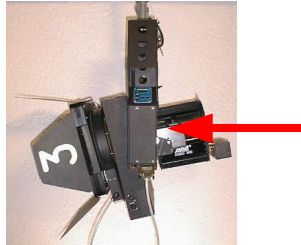

Do not push, pull or drag

That applies also to the **transport**. It is absolutely forbidden to hang up the yoke on its spigot when transported!

If you want to use a transport **carriage**, it must be certified by Licht-Technik!

The fastening spigot must be **checked visual** once a year. The spigot must be in right angel to the housing. This must be checked in **front** and **side** view. A **protractor** can be a help.



Furthermore, the **spigot** itself and the **surface** of the yoke must not be deformed. Make sure that the spigot is not loose or unformal.

If the spigot is visibly **damaged** or deformed the motoryoke must not be used anymore. The device has to be sent to Licht-Technik.

A safety device that was **once loaded** or is visibly damaged **must not** be used anymore!

When working on the motoryoke, it must be **switched off** or the power line must be interrupted. Make sure that the Motoryoke cannot be moved by the control panel.

The operator must make sure that **no person** is in the swivelling range of the motoryoke. Inform your coworker and colleagues that the motoryoke is behaving like a work robot. When the position is changed at the control panel the device is trying to move on this position. There is the danger of being bruised and get frightened.

Admissible ambient **temperature**: 0..45 degree Celsius.

The motoryoke must not be **lit directly** by the lamp. Limit the range of rotation (TILT axle) so that the headlight **does not shine** on the motoryoke.

Check the whole swivelling range of the headlight. The manufacturers of the lamps specify **minimum permissible distances** to inflammable materials. Make sure that these distances are attended in every position of the lamp.

The manufacturers of the lamps specify maximum **inclination**. HMI headlights are not allowed to operate with the ignition electronic on the top.

The motoryoke must be kept **dry**. In case of water condensation a waiting period of up to 2 hours is necessary until acclimatisation is reached.

If **knobs** for manual moving are mounted, they can only be used if the motoryoke is in power off condition. If the device is switched on and the knobs are rotated manually the motors and/or gearboxes can be damaged.

Power supply of Licht-Technik Motoryokes via the DataPower input must only be realised via power supplies **authorised** by us (safe electrical separation from the mains).

The motoryoke is **balanced** in the factory with all (optional) additional devices (color changer and/or dimmer shutter and/or barndoor and/or Focus). The motoryoke must only be operated with this additional devices to keep the balance, otherwise the motor and/or gearbox can be damaged.

Observe the right cabling. The cable-loop must be wide enough and the correct cable-route must be observed. The cables with the safety belt are last fixed left beside the safety hole of the motoryoke. The cable package is routed over the mounting bridge and under the pipe of the rigg:



Wrong routed cables can lead to defective cables, because of the mechanical and thermic influence!

Check the complete pan moving range before starting the equipment by turning by hand! Too short cable loops can block the pan axis!

When it has to be assumed that a **safe operation** is no longer possible, the equipment must be switched off immediately and be **secured against unintended** operation.

This is the case when

- the equipment shows visible damages
- the equipment is no longer functional
- parts of the equipment are loose or slackened
- connecting lines show visible damages

Attention:

Before starting the equipment the user must check the usefulness of the device for its intended use.

We reject every **liability**:

- Damages and indirect damages or every kind of costs, which result from the use of Licht-Technik products.
- Any damages which result from negligence, improper use and setup, wrong setting into operation and use, ignoring of valid safety regulations, unsuitable use, bad maintenance of Licht-Technik products.

The DMX-standard in lighting

Because of many problems with **analogue** data-signals from the control panels to the dimmers the DMX-standard was developed in 1990. DMX only needs **two** wires to control up to 512 dimmers digitally. On the other hand, the old analogue method needs one wire for every dimmer. Many kilometers of cable have been saved.

The DMX-signal is based on the industrial **RS485** interface. It is designed for maximum lengths up to 1200m. Normally this length is under condition in theatre or studio **not possible** (strong electrical fields because of the HMI lamps). As a result of internal tests we recommend a maximum length of **200m** (only DMX line, 5pin). On every DMX transmitter a maximum of 32 DMX receiver can be connected. All devices must be connected in a **row** (cabling from A to B, from B to C, from C to D etc.). The last device in such a row must be terminated with a resistor (470 Ohm). If more than 32 devices should be connected a booster or **splitbox** must be inserted.

A **splitbox** is a device with one DMX input and several DMX outputs. The signal is refreshed. Thus it is possible to use different DMX lines.

The reliability of data transmission was increased because of using DMX. One of the greatest advantages is universal usefulness. Now devices from different manufacturers can be controlled by every control panel.

Cabling

Caution!

Please read the operating and safety instructions on page 6 (continuing) before cabling!

Make sure that the motoryoke is **switched off** before cabling!

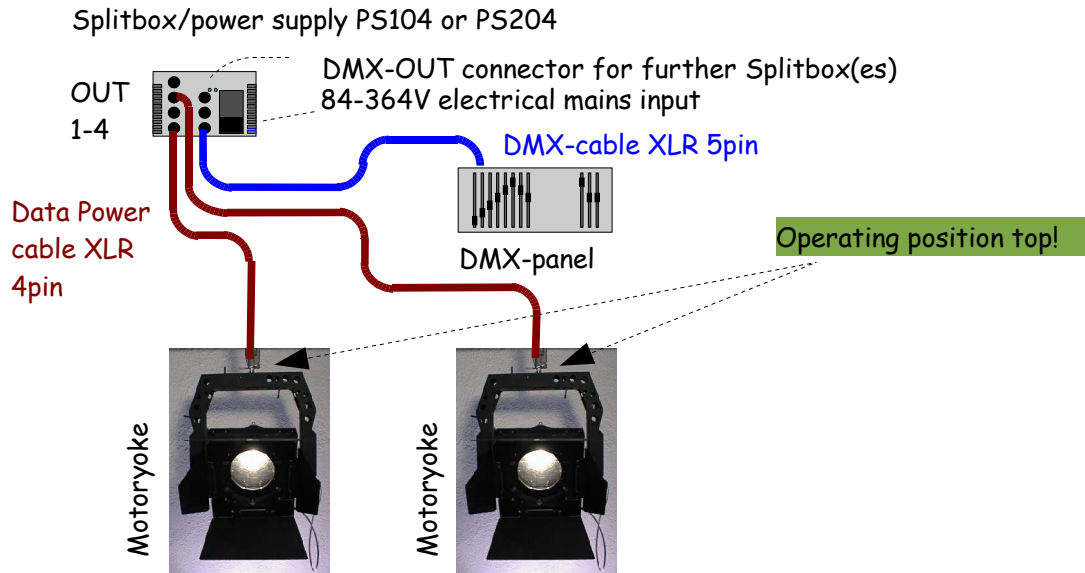

For pinout of cables refer to *technical data*, page 45.

Make sure that the connected power does **not exceed** the maximum power output of the power supply. Keep shutters and color changers in mind which are possibly connected. The maximum required power per device is always given on the identification plate. All devices together, which are connected to the power supply, must not exceed the power output of the power supply.

If only motoryokes should be connected, use this table:

Device	Power	Number of motoryokes
PS154	360W	3
PS254	600W	5

Caution!!

Make a **loop**, which is large enough, in the data power cable and the lamp cable. Make sure that there is enough space in cabling over the entire moving range of the yoke. The cables must neither be **stretched** nor **bended**!

The cables are fixed with cable fixers. The clips are mounted on the back side of the yoke.

It is possible to connect a Licht-Technik color changer and/or a dimmer-shutter. The last device of a DMX-chain should be terminated with a terminating resistor (470 Ohm). The maximum length of a DMX-chain must not exceed 80m.
Furthermore a **motorised barndoor** (25pin Sub-D)

Getting started

The motoryoke is **balanced** in factory for the desired lamp with optional accessories (shutter, color changer, barndoor, Focus, power switching). The yoke must only be operated with this lamp and accessories. The accessories must not be removed, because this changes the balance. The motors and gearboxes can be damaged.

Setup the motoryoke on the desired place **according** to the *operating and safety instructions, page 6*.

Cable the motoryoke like illustrated in *cabling, page 10*.

Switch on the motoryoke. After testing its internal program memory and the control it shows the overall operating hours. Now the motoryoke is moving to the programmed position. The second display line shows the DMX-address and value of the PAN-axle.

Caution!

Make sure that the motoryoke is not moved by the **control panel** before programming. Otherwise the motoryoke will move during programming if the position is changed at the panel!

Program the **moving range** of the **PAN-axle**. Refer to *PAN-axle moving range, page 12*.

Normally not necessary, but possible is the programming of the **TILT moving range**. Refer to *TILT-axle moving range, page 14*.

Further programming possibilities like DMX addressing are specified on the following pages.

Tip:

When the motoryoke is in **programming mode**, all moving orders are ignored. Make sure that the device is in operating mode after programming, otherwise it will not move! Press two times the OK key for leaving the programming mode!

PAN – axis moving range

Basically:

The PAN-axis is the axle which moves the lamp **horizontally**.

The **moving range** of the main axes can be adapted individually. For the PAN-axis are two parameters required. The **middle position** and an **angle** in which the motoryoke should move. Is an angle of 90 degrees programmed the motoryoke moves from its middle position 90° to the left and 90° to the right. The whole moving range is 180°.

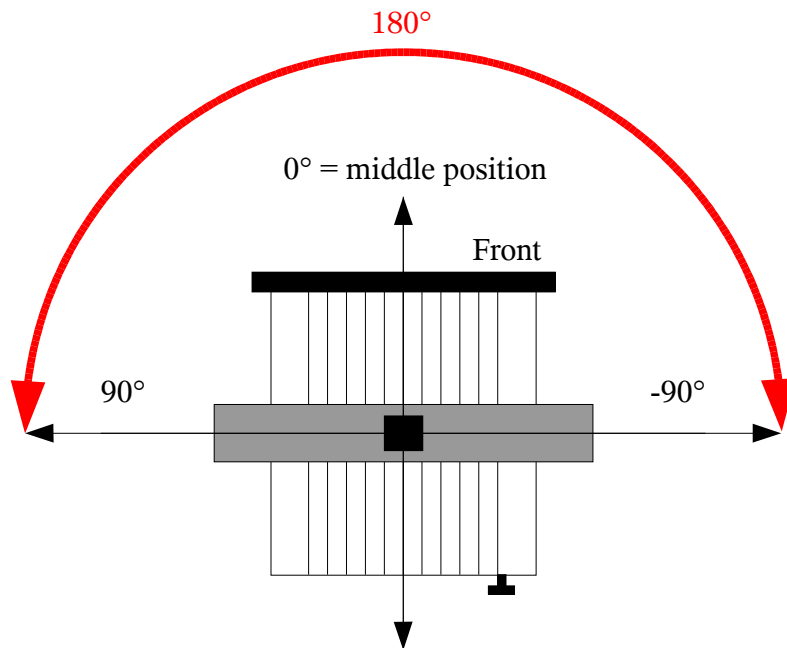

If an angle of 45° is programmed, the yoke will move 45° to the left and right. The moving range is 90°.

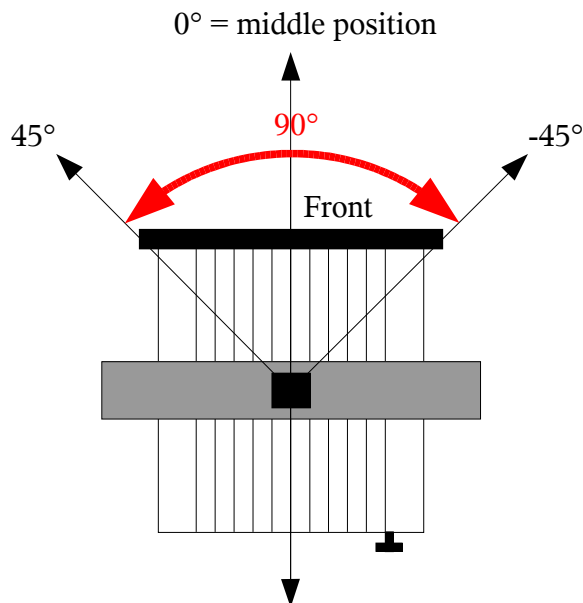

This setup is useful when the motoryoke is hanging in a **corner** for example.

Setting the PAN middle position:

The middle position normally is the position in which the lamp is **used most**. For programming, set the DMX-value of the PAN-axle and the PAN-axle-speed to **50%**. These are channels 1 and 5 at factory presettings.

Let yoke move onto this position. After that the middle position can be set. Exert the **tripping lever** with a small screwdriver. Turn the yoke **carefully** on its arms onto the desired middle position. Keep the tripping lever pressed.

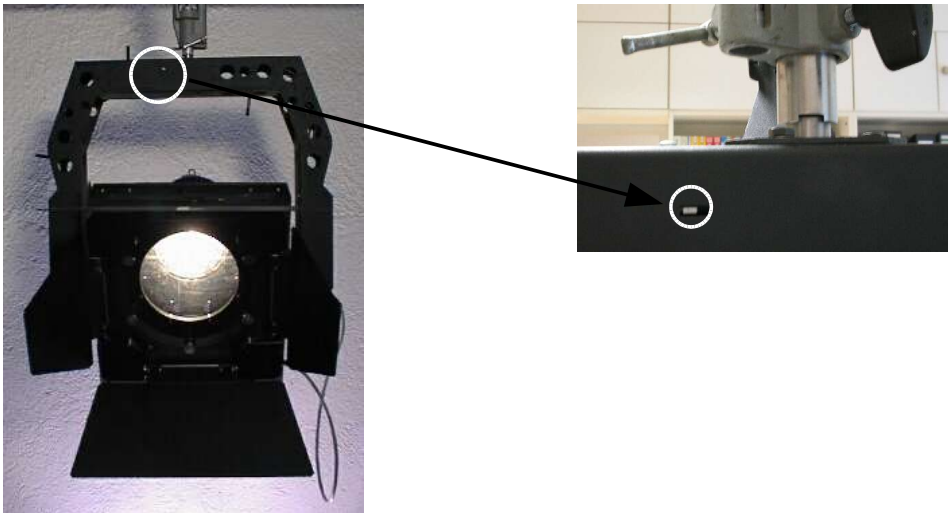

For understanding: Because of exerting the tripping lever, the motoryoke remains **internally** on its middle position. The absolute value device does not join in turning anymore. You turn the yoke around this internal middle position.

Testing of the new setting: Change the DMX-value of the PAN-axle for a few seconds, after that set it back to 50%. The motoryoke moves to its new middle position. The rough position is now programmed. In menu P05, PAN-axle middle position, page 21 the fine adjustment can be done.

The **moving angle** can be set in menu *P11, PAN-axle moving range, page 24*. It can be in a range within 1 and 185°.

Caution !!

Check the **entire moving** range of the lamp:

The lamp-manufacturer specify **minimum distances** to inflammable materials. Never fall below the minimum distance in no position of the lamp!

Make sure that no cable will be **broken, bended, stretched** or **damaged** anyhow by reason of turning the motoryoke!

TILT – axis moving range

Basically:

The TILT-axis is the axle which moves the lamp **vertically**.

Normally the factory presettings are **suitable** and nothing must be set. The lamp can be moved from vertically down to a few degrees on the top.

The 0-degree position represents the **horizontal even** position of the lamp. From this position a **positive** moving range and a **negative** moving range is defined. The positive range is much smaller than the negative range. This is the reason why it can not be determined where the 50% DMX position is.

TILT moving range is in opposite to the PAN moving range asymmetric. It is set in two menus. (P12, page 25 and P13 page 26).

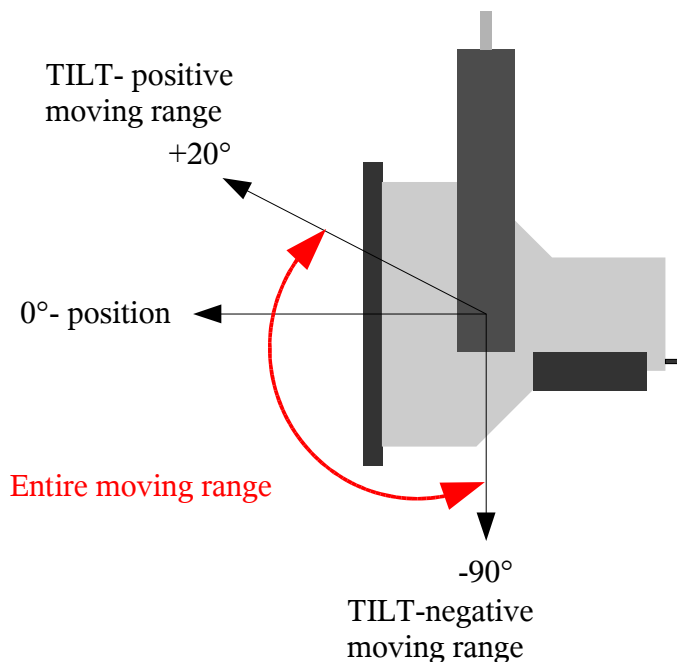

If a correction must be made do proceed with the following steps:

Use menu *P06, TILT-axle 0-position, page 22*, to move the yoke onto 0-position. When the value is changed one time (up or down), the yoke starts moving on this position.

Wait until the motoryoke **does not move** anymore.

Now it is possible to set a **new 0-position** by exerting the tripping lever. Another possibility is to use *P06, TILT-axle 0-position, page 22*.

Using the tripping lever:

Push in the lever on the front side of the yoke with a screwdriver. Keep it depressed and move the lamp onto the desired 0-position. Change the value of P06 one time. The motoryoke will move exactly onto the new 0-position.

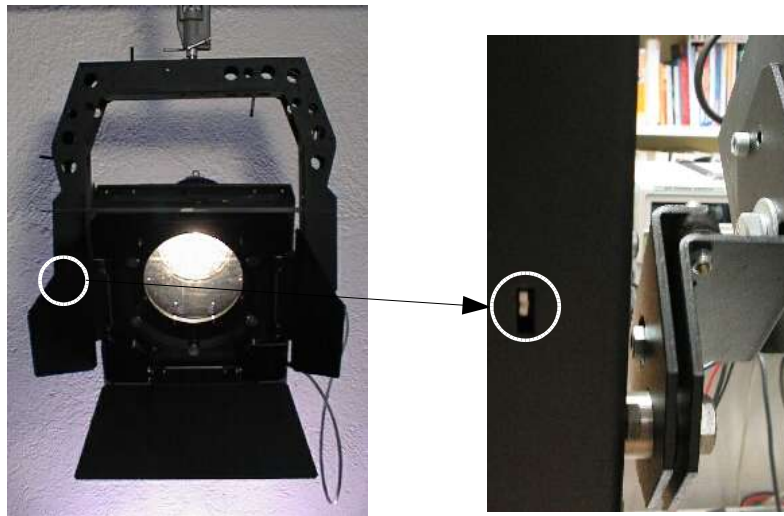

Now the **angles** for the moving range in P12 and P13 can be set. New reference point is the 0-position from before.

Do not forget to press **two** times the **OK** key to get back to working level after programming.

Check the complete new moving range with the **DMX-signal**.

Caution !!

Check the entire **moving range** of the lamp:

The lamp-manufacturer specify **minimum distances** to inflammable materials. Never fall below the minimum distance in no position of the lamp!

Check that the **motoryoke** will not be illuminated when lamp is on top position.

Make sure that no cable will be **broken, bended, stretched** or **damaged** anyhow by reason of turning the motoryoke!

Headlights generally must **not** be operated with the ignition electronic on the top. Observe the specifications of the lamp manufacturer!

User interface

Moving text with type of device, software-version and telephone number

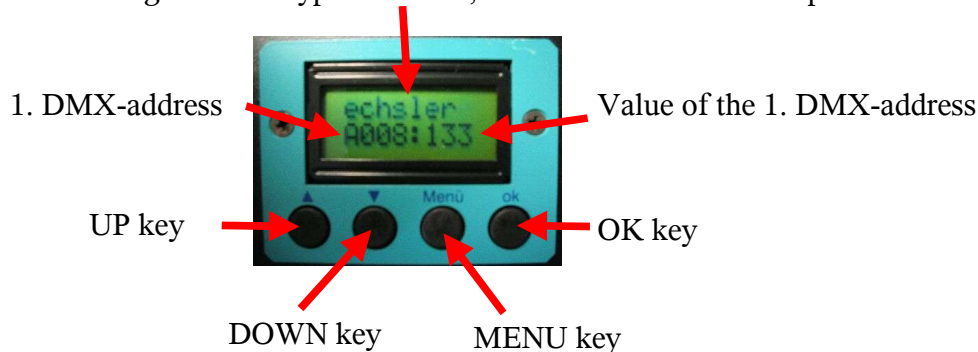

In normal operating mode the **LCD-display** indicates different information. The first line shows the Licht-Technik moving text with details on type of device, software version and telephone number. The second line indicates the first DMX-address and its incoming value (8-Bit, 0..255). For the motoryoke, this address is the PAN-address.

With the four **keys** the device can be programmed. Instruction for this, is on the following pages.

Display lighting ON/OFF

In normal operation the LCD backlight is switched off to avoid a disturbing light. Only if an error occurs or during programming the light will be switched on automatically. The user can also switch it on manually to see what is indicated.

Condition: Motoryoke is on working level

Operation:



depress. Display lighting **ON**



depress again. Display lighting **OFF**

DMX channels motoryoke

The following chapters require the **DMX-channel assignment** of the motoryoke. Please note the difference which is programmed in *P27, PAN/TILT DMX speed channel setup, page 36*. This menu determines if the speed is given by **one** or by **two** channels. Therefore, the motoryoke requires between 5 (without optional components) and 12 DMX-channels.

Channel	Motoryoke (P27=0)	Motoryoke (P27=1)
1	Rotation PAN rough	Rotation PAN rough
2	Rotation PAN fine	Rotation PAN fine
3	Rotation TILT rough	Rotation TILT rough
4	Rotation TILT fine	Rotation TILT fine
5	PAN/TILT speed	PAN speed
6	Rotation lamp	TILT speed
7	Motorized barndoor, leaf 1 (optional)	Rotation lamp
8	Motorized barndoor, leaf 2 (optional)	Motorized barndoor, leaf 1 (optional)
9	Motorized barndoor, leaf 3 (optional)	Motorized barndoor, leaf 2 (optional)
10	Motorized barndoor, leaf 4 (optional)	Motorized barndoor, leaf 3 (optional)
11		Motorized barndoor, leaf 4 (optional)
12	-----	

The **first** address (PAN rough) is set in menu *P01, DMX-address motoryoke, page 18*. All other addresses **follow** after this first address according to this table.

Examples:









1. Motoryoke with **all** optional components and P27 set to 1 (like right column in table). The next free DMX-channel would be number **12**.
2. Motoryoke **without** any additional components and P27 set to 0. Next free channel would be channel **7**.
3. Motoryoke with motorized **barndoor** and P27 set to 0. The next free channel is number **11**.

P01 DMX-Address motoryoke

At this point the **first** DMX-address of the motoryoke can be adapted to the desired DMX-address of the light mixing panel. This address represents the PAN-DMX-address. All other addresses follow this address. Refer to *DMX-channels motoryoke, page 17*.

Range of values: Address 1..512

Operation:









-  depress You are now on menu level. The last adjusted menu point is displayed, e.g.:
Menu F02: Focus module on/off
-   depress ... until Menu P01 is displayed.
-  depress The second line displays the currently adjusted value.
-   depress Adjust the desired DMX address.
-  depress You are back on menu level.
-  depress The equipment is ready for operation.

P02 Lamp rotation ON/OFF

At this point the lamp rotation function can be switched ON or OFF. If no lamp rotation is required, set this value to 0. The speed of the rotation is fixed, so no speed channel has to be set.

Range of values: 0: No lamp rotation required
1: Lamp rotation is switched on

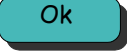
Operation:







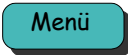

-  depress You are now on menu level. The last adjusted menu point is displayed, e.g.:
Menu P01: DMX address motoryoke
-   depress ... until Menu P02 is displayed.
-  depress The second line displays the currently adjusted value.
-   depress Adjust the desired value
-  depress You are back on menu level.
-  depress The equipment is ready for operation.

P03 Motorised barndoor ON/OFF

At this point an optional **barndoor** can be switched ON or OFF. If a Licht-Technik barndoor is mounted set this menu to 1, on the other hand if no barndoor is mounted set this menu point to 0. The speed of the barndoors and barndoor-rotation is fixed, so no speed channel has to be set.

Range of values: 0: No barndoor installed
1: barndoor installed

Operation:

-  depress You are now on menu level. The last adjusted menu point is displayed, e.g.:
Menu P01: DMX address motoryoke
-   depress ... until Menu P03 is displayed.
-  depress The second line displays the currently adjusted value.
-   depress Adjust the desired value
-  depress You are back on menu level.
-  depress The equipment is ready for operation.







P05 PAN-axis middle position

With this function the **PAN-axis fine adjustment** of the middle position can be made. Please read first chapter *PAN-axis moving range*, page 12. This function can only be used for **fine** adjustment.

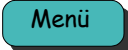
Range of values: 2000..2100 unit (value of the absolute value device)

Recommended value: 2048

Operation:

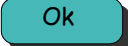
-  depress You are now on menu level. The last adjusted menu point is displayed, e.g.:
Menu P01: DMX address motoryoke
-   depress ... until Menu P04 is displayed.
-  depress The second line displays the currently adjusted value.
-   depress Adjust the desired value. The motoryoke moves to the indicated position.
-  depress You are back on menu level.
-  depress The equipment is ready for operation.

P06 TILT-axis 0-position



With this function the **TILT-axis fine adjustment** of the 0-position can be made. Please read first chapter *TILT-axis moving range*, page 14. This function can only be used for **fine** adjustment.

Range of values: 2000..2100 unit (value of the absolute value device)

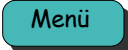

Recommended value: 2048

Operation:

-  depress You are now on menu level. The last adjusted menu point is displayed, e.g.:
Menu P01: DMX address motoryoke

-   depress ... until Menu P06 is displayed.

-  depress The second line displays the currently adjusted value.

-   depress Adjust the desired value. The motoryoke moves to the indicated position.

-  depress You are back on menu level.

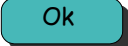
-  depress The equipment is ready for operation.

P07 Barndoor rotation middle position

No function at this point. Value has no effect. Barndoor rotation is done by lamp rotation.

P11 PAN-axis moving range







At this point the **PAN-axis moving range** can be programmed. The moving range has as reference point the PAN-axis middle position which can be set in P05, *PAN-axis middle position, page 21*. For example: If this menu is programmed to 90°, the motoryoke moves 90° to the left **and** 90° to right from middle position.

Before programming this point read chapter *PAN-axis moving range, page 12* and *P05 PAN-axis middle position, page 21!*

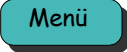
Range of values: 10..182 degrees

Recommended value: 90°

Operation:

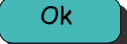
-  depress You are now on menu level. The last adjusted menu point is displayed, e.g.:
Menu P01: DMX address motoryoke
-   depress ... until Menu P11 is displayed.
-  depress The second line displays the currently adjusted value.
-   depress Adjust the desired moving range
-  depress You are back on menu level.
-  depress The equipment is ready for operation.

Caution !!

Check the **entire moving** range of the lamp:

The lamp-manufacturer specify **minimum distances** to inflammable materials. Never fall below the minimum distance in no position of the lamp!

Make sure that no cable will be **broken, bended, stretched** or **damaged** anyhow by reason of turning the motoryoke!

P12 TILT-down (negative) moving range







At this point the **TILT-down moving range** can be set. For the TILT-axis the moving ranges (up and down) must be programmed individually. The negative moving range is defined as the „direction bottom“ range. The moving ranges have the 0-position as reference point. This point can be set in *P06, TILT-axis 0-position, page 22*.

Before programming this point read chapter *TILT-axis moving range, page 14* and *P06, TILT-axis 0-position, page 22!*

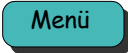
Range of values: 10..182 degrees

Recommended value: 90°

Operation:

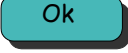
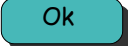
-  depress You are now on menu level. The last adjusted menu point is displayed, e.g.:
Menu P01: DMX address motoryoke
-   depress ... until Menu P12 is displayed.
-  depress The second line displays the currently adjusted value.
-   depress Adjust the desired moving range
-  depress You are back on menu level.
-  depress The equipment is ready for operation.

Caution !!

Check the entire **moving range** of the lamp:

The lamp-manufacturer specify **minimum distances** to inflammable materials. Never fall below the minimum distance in no position of the lamp!

Check that the **motoryoke** will not be lit when lamp is on top position.

Make sure that no cable will be **broken, bended, stretched** or **damaged** anyhow by reason of turning the motoryoke!

Headlights generally must **not** be operated with the ignition electronic on the top. Observe the specifications of the lamp manufacturer!

P13 TILT-up (positive) moving range







At this point the **TILT-up moving range** can be set. For the TILT-axis the moving ranges (up and down) must be programmed individually. The positive moving range is defined as the „direction top“ range. The moving ranges have the 0-position as reference point. This point can be set in *P06, TILT-axis 0-position, page 22*.

Before programming this point read chapter *TILT-axis moving range, page 14* and *P06, TILT-axis 0-position, page 22!*

Range of values: 10..182 degrees

Recommended value: 20°

Operation:

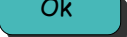
-  depress You are now on menu level. The last adjusted menu point is displayed, e.g.:
Menu P01: DMX address motoryoke
-   depress ... until Menu P13 is displayed.
-  depress The second line displays the currently adjusted value.
-   depress Adjust the desired moving range
-  depress You are back on menu level.
-  depress The equipment is ready for operation.

Caution !!

Check the entire **moving range** of the lamp:

The lamp-manufacturer specify **minimum distances** to inflammable materials. Never fall below the minimum distance in no position of the lamp!

Check that the **motoryoke** will not be lit when lamp is on top position.

Make sure that no cable will be **broken, bended, stretched** or **damaged** anyhow by reason of turning the motoryoke!

Headlights generally must **not** be operated with the ignition electronic on the top. Observe the specifications of the lamp manufacturer!

P14 Lamp rotation 0%-value adjustment

At this point the **position of the lamp rotation for 0% DMX-value** can be set.







This function is only available, when lamp rotation function is switched on. This can be done in menu *P02, Focus module ON/OFF, page 19*.

Caution!

The 0%-value must be smaller than the the 100%-value! (P14 smaller than P15)

Range of values: 10..4000 units (value of the absolute value device)

Operation:

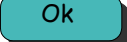
-  depress You are now on menu level. The last adjusted menu point is displayed, e.g.:
Menu P01: DMX address motoryoke
-   depress ... until Menu P14 is displayed.
-  depress The second line displays the currently adjusted value.
-   depress Adjust the desired value
-  depress You are back on menu level.
-  depress The equipment is ready for operation.

P15 Lamp rotation 100%-value adjustment

At this point the **position of the lamp rotation for 100% DMX-value** can be set.







This function is only available, when lamp rotation is switched on. This can be done in menu *P02, Focus module ON/OFF, page 19*.

Caution!

The 100%-value must be greater than the 0%-value! (P15 greater than P14)

Range of values: 10..4000 units (value of the absolute value device)

Operation:

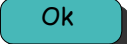
-  depress You are now on menu level. The last adjusted menu point is displayed, e.g.:
Menu P01: DMX address motoryoke
-   depress ... until Menu P15 is displayed.
-  depress The second line displays the currently adjusted value.
-   depress Adjust the desired value
-  depress You are back on menu level.
-  depress The equipment is ready for operation.

P16 Barndoor 1 closed position

At this point the **barndoor 1 position for 0% DMX-value** can be set.

This function is only available, when barndoor is switched on. This can be done in menu *P03, motorized barndoor ON/OFF, page 20*.







Guideline!

You should adjust the barndoors in this order: 4 3 2 1 !

You have the possibility to set this value automatically. When depressing the menu button again (see operation), the barndoor moves to the mechanical stop and stops moving. Now the barndoor should be moved by depressing the UP-key until there is a little gap (around 1mm) between barndoor and housing/other barndoor.

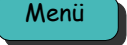
Range of values: 10..4000 units (value of the absolute value device)

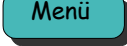
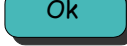
Operation:

-  depress You are now on menu level. The last adjusted menu point is displayed, e.g.:
Menu P01: DMX address motoryoke
-   depress ... until Menu P16 is displayed.
-  depress The second line displays the currently adjusted value.
-   depress Adjust the desired value
or
-  depress for automatic movement to the mechanical stop.
Corrections with UP/DOWN keys are still possible.
-  depress You are back on menu level.
-  depress The equipment is ready for operation.

P18 Barndoor 2 closed position

At this point the **barndoor 2 position for 0% DMX-value** can be set.

This function is only available, when barndoor is switched on. This can be done in menu *P03, motorized barndoor ON/OFF, page 20*.







Guideline!

You should adjust the barndoors in this order: 4 3 2 1 !

You have the possibility to set this value automatically. When depressing the menu button again (see operation), the barndoor moves to the mechanical stop and stops moving. Now the barndoor should be moved by depressing the UP-key until there is a little gap (around 1mm) between barndoor and housing/other barndoor.

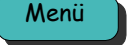
Range of values: 10..4000 units (value of the absolute value device)

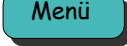
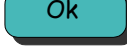
Operation:

-  depress You are now on menu level. The last adjusted menu point is displayed, e.g.:
Menu P01: DMX address motoryoke
-   depress ... until Menu P18 is displayed.
-  depress The second line displays the currently adjusted value.
-   depress Adjust the desired value
or
-  depress for automatic movement to the mechanical stop.
Corrections with UP/DOWN keys are still possible.
-  depress You are back on menu level.
-  depress The equipment is ready for operation.

P20 Barndoor 3 closed position

At this point the **barndoor 3 position for 0% DMX-value** can be set.

This function is only available, when barndoor is switched on. This can be done in menu *P03, motorized barndoor ON/OFF, page 20*.







Guideline!

You should adjust the barndoors in this order: 4 3 2 1 !

You have the possibility to set this value automatically. When depressing the menu button again (see operation), the barndoor moves to the mechanical stop and stops moving. Now the barndoor should be moved by depressing the UP-key until there is a little gap (around 1mm) between barndoor and housing/other barndoor.

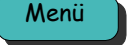
Range of values: 10..4000 units (value of the absolute value device)

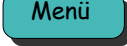
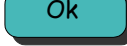
Operation:

-  depress You are now on menu level. The last adjusted menu point is displayed, e.g.:
Menu P01: DMX address motoryoke
-   depress ... until Menu P20 is displayed.
-  depress The second line displays the currently adjusted value.
-   depress Adjust the desired value
or
-  depress for automatic movement to the mechanical stop.
Corrections with UP/DOWN keys are still possible.
-  depress You are back on menu level.
-  depress The equipment is ready for operation.

P22 Barndoor 4 closed position

At this point the **barndoor 3 position for 0% DMX-value** can be set.

This function is only available, when barndoor is switched on. This can be done in menu *P03, motorized barndoor ON/OFF, page 20*.







Guideline!

You should adjust the barndoors in this order: 4 3 2 1 !

You have the possibility to set this value automatically. When depressing the menu button again (see operation), the barndoor moves to the mechanical stop and stops moving. Now the barndoor should be moved by depressing the UP-key until there is a little gap (around 1mm) between barndoor and housing/other barndoor.

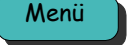
Range of values: 10..4000 units (value of the absolute value device)

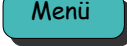
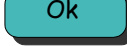
Operation:

-  depress You are now on menu level. The last adjusted menu point is displayed, e.g.:
Menu P01: DMX address motoryoke
-   depress ... until Menu P22 is displayed.
-  depress The second line displays the currently adjusted value.
-   depress Adjust the desired value
or
-  depress for automatic movement to the mechanical stop.
Corrections with UP/DOWN keys are still possible.
-  depress You are back on menu level.
-  depress The equipment is ready for operation.





P23 Barndoor 1..4 moving range

With this function the **opening angle** of all barndoors can be set. This adjustment is for all 4 barndoors.

This function is only available, when barndoor is switched on. This can be done in menu *P03, motorized barndoor ON/OFF, page 20*.

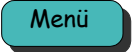
Range of values: 10..130 degrees

Operation:

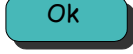
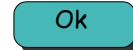
-  depress You are now on menu level. The last adjusted menu point is displayed, e.g.:
Menu P01: DMX address motoryoke
-  depress ... until Menu P23 is displayed.
-  depress The second line displays the currently adjusted value.
-  depress Adjust the desired moving range
-  depress You are back on menu level.
-  depress The equipment is ready for operation.

P24 All barndoors closed position adjustment



With this function, you can set the closed position of the barndoors at once and automatically. It is much faster but less precise than the menus P16, P18, P20 and P22.

This function is only available, when barndoor is switched on. This can be done in menu *P03, motorized barndoor ON/OFF, page 20*.

Before using this function, please **close** all barndoors via the lighting desk. After that call menu P24 as follows!

Operation:

 depress You are now on menu level. The last adjusted menu point is displayed, e.g.:
Menu P01: DMX address motoryoke

  depress ... until Menu P24 is displayed.

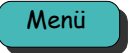
 depress The display indicates the four potentiometer values.

Press with your finger on the top barndoor 1.

Wait until the potentiometer values have been reached a constant value.

 depress The positions are saved.

 depress You are back on menu level.

 depress The equipment is ready for operation.

P25 Barndoor rotation moving range

No function at this point. Value has no effect. Barndoor rotation is done by lamp rotation.

P27 Speed PAN/TILT setup

At this point the number of **speed channels** can be set. The speed for PAN and TILT axis can be programmed to one channel for both axis or to two channels. One for each axis.









When using the Licht-Technik control panels with Joystick, this Parameter must be set to 1.

Caution!

The **order of DMX-channels** is changed with this function! Refer to *DMX-channels motoryoke, page 17*.

Range of values: 0: Speed PAN and TILT together. One DMX-channel.
1: Speed PAN and TILT separated. Two DMX-channels.

Operation:

-  depress You are now on menu level. The last adjusted menu point is displayed, e.g.:
Menu P01: DMX address motoryoke
-   depress ... until Menu P27 is displayed.
-  depress The second line displays the currently adjusted value.
-   depress Adjust the desired value.
-  depress You are back on menu level.
-  depress The equipment is ready for operation.

P28 Barndoor automove function ON/OFF

In this menu the automove **function** can be switched ON or OFF.

If **2 or more** barndoors are moved (opened or closed makes no difference) at once, the control unit can calculate the right moving order to avoid crashes (if this menu is set to 1).

When closing, the barndoors are moved in this order: 4, 3, 2, 1.

When opening, the barndoors are move in the inverse order: 1, 2, 3, 4.



But: If only one barndoor is moved a crash can occur! E.g.: It will crash if all barndoors closed and only moving number 1!

This function is only available, when barndoor is switched on. This can be done in menu *P03, motorized barndoor ON/OFF, page* .



Range of values: 0: Automove function **off**
1: Automove function **on**

Operation:

-  depress You are now on menu level. The last adjusted menu point is displayed, e.g.:
Menu P01: DMX address motoryoke

-   depress ... until Menu P28 is displayed.

-  depress The second line displays the currently adjusted value.

-   depress Adjust the desired value.

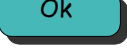
-  depress You are back on menu level.

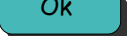





-  depress The equipment is ready for operation.

P30 Displaying the DMX-value

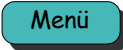
This function assists you in **checking** the values transmitted by the light mixer panel. At this point you can quickly detect whether the motoryoke is triggered with the **correct** values. It is possible to check all 512 DMX channels. Note that the value of the address programmed in this menu will be indicated in normal operation. After power up the programmed address in menu P01 (page 18) will be displayed.

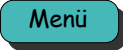
Range of values: Address 1..512

Operation:

-  depress You are now on menu level. The last adjusted menu point is displayed, e.g.:
Menu P01: DMX address motoryoke
-   depress ... until Menu P30 is displayed.
-  depress The second line displays the currently adjusted value.
-   depress Adjust the desired address.
-  depress You are back on menu level.
-  depress The equipment is ready for operation.



P32 Selecting the user language

At this point you can choose in which language the texts and messages should be displayed.



Range of values: 0 = German
 1 = English

Operation:

 depress You are now on menu level. The last adjusted menu point is displayed, e.g.:
 Menu P01: DMX address motoryoke

  depress ... until Menu P32 is displayed.

 depress The second line displays the currently adjusted value.

  depress Adjust the desired language.

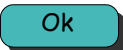
 depress You are back on menu level.

 depress The equipment is ready for operation.

P36 Interchanging PAN moving direction

With this function the **PAN moving direction** can be set.

Range of values: 0 = normal (standard)
1 = reverse direction

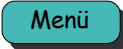

Recommended value: 0

Operation:

 depress You are now on menu level. The last adjusted menu point is displayed, e.g.:
Menu P01: DMX address motoryoke

  depress ... until Menu P36 is displayed.

 depress The second line displays the currently adjusted value.

  depress Adjust the desired direction.

 depress You are back on menu level.

 depress The equipment is ready for operation.

P37 Interchanging TILT moving direction

With this function the **TILT moving direction** can be set.

Range of values: 0 = normal (standard)
1 = reverse direction

Recommended value: 0

Operation:

 depress You are now on menu level. The last adjusted menu point is displayed, e.g.:
menu P01: DMX address motoryoke

  depress ... until Menu P37 is displayed.

 depress The second line displays the currently adjusted value.

  depress Adjust the desired direction.

 depress You are back on menu level.

 depress The equipment is ready for operation.







P38 Interchanging lamp rotation moving direction

With this function the **lamp rotation direction** can be set.

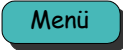
Range of values: 0 = normal (standard)
1 = reverse direction

Recommended value: 0

Operation:

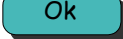
-  depress You are now on menu level. The last adjusted menu point is displayed, e.g.:
Menu P01: DMX address motoryoke
-   depress ... until Menu P38 is displayed.
-  depress The second line displays the currently adjusted value.
-   depress Adjust the desired direction.
-  depress You are back on menu level.
-  depress The equipment is ready for operation.

P39 Interchanging barndoor rotation moving direction

No function at this point. Value has no effect. Barndoor rotation is done by lamp rotation.



P40 Unit number Netspider

With this function you can set the **unit number** for Netspider systems.



Range of values: 0..9999

Operation:

 depress You are now on menu level. The last adjusted menu point is displayed, e.g.:
Menu P01: DMX address motoryoke

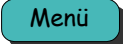
  depress ... until Menu P35 is displayed.

 depress The second line displays the currently adjusted value.

  depress Adjust the desired unit number.

 depress You are back on menu level.

 depress The equipment is ready for operation.

Technical data

Weights and dimensions:

The identification number is described on page 5.

MB-	Width [cm]	Height [cm]	Depth [cm]	Weight [kg]	max. load [kg]
S60	57,5	45	12	14,8	40

Connected loads: 24 V DC, max. 5 A

Fuse: 6.3 A slow blow

Pin assignment:

Data-Power-cable: 4pin XLR connector screened

Housing: Screen

PIN 1: 0 V (GND) min. cross section 0,75mm²

PIN 2: DMX-Data – min. cross section 0,25mm²

PIN 3: DMX-Data + min. cross section 0,25mm²

PIN 4: +24 V DC min. cross section 0,75mm²

The DMX wires must be twisted pair and shielded separately.

Barndoor cable:

Pin number	Signal	Pin number	Signal
Pin 1	Motor barndoor rot -	Pin 13	Not connected
Pin 2	Motor barndoor 4 -	Pin 14	Motor barndoor rot +
Pin 3	Motor barndoor 3 -	Pin 15	Motor barndoor 4 +
Pin 4	Motor barndoor 2 -	Pin 16	Motor barndoor 3 +
Pin 5	Motor barndoor 1 -	Pin 17	Motor barndoor 2 +
Pin 6	GND (ground)	Pin 18	Motor barndoor 1 +
Pin 7	Potentiometer barndoor 2	Pin 19	Potentiometer barndoor 1
Pin 8	Not connected	Pin 20	Potentiometer GND
Pin 9	Potentiometer barndoor 3	Pin 21	Potentiometer barndoor 4
Pin 10	Potentiometer Vcc (+5V)	Pin 22	Potentiometer barndoor rot
Pin 11	Not connected	Pin 23	GND
Pin 12	Not connected	Pin 24	Not connected
		Pin 25	Not connected

Readjustment of motoryoke axis

Caution!

Only for **Licht-Technik** trained personal!

These works can only be done in a **well equipped workshop**. It is absolutely **forbidden** to do these works on **ladders** or **lifts**!

If a potentiometer has to be changed or disassembled, an adjustment of the potentiometer is necessary, please follow these instructions:

Readjustment PAN-axis:

1. Move the **powered off** motoryoke onto **middle** position of the PAN-moving range.
2. Put the Potentiometer onto the **half** printed resistor value. Check it with an Ohmmeter.
3. **Install** the Potentiometer.
4. Set the DMX-value for PAN-axis to **50%**.
5. Switch on the motoryoke **without DMX-Signal** (disconnect DMX-IN cable at power-supply/splitbox). Thus the motoryoke remains on its momentary position.
6. Set the **middle** position for PAN-axis(*P05, PAN-axis middle position, page 21*) to 2048. (default value).
7. Connect the **DMX-signal** again.
8. The motoryoke moves to **50%** DMX-position. Now the adjustment of the PAN-axis middle position can be set. (*PAN – axis moving range, page 12*).
9. Maybe the moving range **angle** must be readjusted. Refer to *PAN – axis moving range, page 12* and *P11 PAN-axis moving range, page 24*.
10. Check the both **end-positions** via the light mixing panel.

Readjustment TILT-axis:

1. Move the **powered off** motoryoke onto **middle** position of the TILT-axis moving range (at default-value about 45 degrees to bottom).
2. Put the Potentiometer onto the **half** printed resistor value. Check it with an Ohmmeter.
3. **Install** the Potentiometer.
4. Set the DMX-value for TILT-axis to **50%**.
5. Switch on the motoryoke **without DMX-Signal** (disconnect DMX-IN cable at power-supply/splitbox). Thus the motoryoke remains on its momentary position.
6. Set the **middle** position for PAN-axis(*P05, PAN-axis middle position, page 21*) to 2048. (default value).
7. Connect the **DMX-signal** again.
8. The motoryoke moves to **50%** DMX-position. Now the adjustment of the TILT-axis middle position can be set. Use menu *P06 TILT-axis 0-position, page 22* and *TILT – axis moving range, page 14*.
9. Maybe the moving range **angle** must be readjusted. Refer to *TILT – axis moving range, page 14* and *P12 TILT - down moving range, page 25* and *P13 TILT-up moving range, page 26*.
10. Check the both **end-positions** via the light mixing panel.

Factory presets

Menu	Description	Value	Info
P01	DMX-address motoryoke	1	
P02	Lamp rotation module ON/OFF	1	
P03	Motorized barndoor ON/OFF	0/1 (individual)	Depends on equipping
P04	DMX-address power switching	individual	
P05	PAN-axis middle position	individual	
P06	TILT-axis 0-position	individual	
P07	Barndoor rotation middle position	individual	No effect
P11	PAN-axis moving range	182 degree	
P12	TILT-down (negative) moving range	90 degree	
P13	TILT-up (positive) moving range	5 degree	
P14	Lamp rotation unit 0% value adjustment	individual	Lamp rotation
P15	Lamp rotation unit 100% value adjustment	individual	Lamp rotation
P16	Barndoor 1 closed position	individual	
P18	Barndoor 2 closed position	individual	
P20	Barndoor 3 closed position	individual	
P22	Barndoor 4 closed position	individual	
P23	Barndoor 1..4 moving range	125 degree	
P25	Barndoor rotation moving range	90 degree	No effect
P27	Speed PAN/TILT setup	0 (1 channel)	
P28	Barndoor autoclose function ON/OFF	1 (ON)	No effect
P30	Displaying DMX-value	1	
P32	Selecting the user language	1 (english)	
P36	Interchanging PAN-moving direction	0	
P37	Interchanging TILT-moving direction	0	
P38	Interchanging Focus-moving direction	0	
P39	Interchanging barndoor rotation PAN-moving direction	0	
P40	Unit number Netspider	0	

Maintenance

By regular maintenance a significant increase of **lifetime** and **reliability** can be achieved.

Regular maintenance increases safety significant!!

We recommend a maintenance once a year.

Obligatory are the following points:

1. Checking the fixing parts:

The fastening spigot must be **checked visual**. The spigot must be in right angel to the housing. This must be checked in **front** and **side** view. A **protractor** can be a help.



Furthermore, the **spigot** itself and the **surface** of the yoke must not be deformed. Make sure that the spigot is not loose.

If the spigot is visibly **damaged** or deformed the motoryoke must not be used anymore. The device has to be sent to Licht-Technik.

2. Checking the safety elements

Check the safetybelts and further safetyelements like shackles, rings, lugs, chains:

- Are the belts not frayed out?
- Are the threads of the shackles okay? Are the screws easy to turn?
- Are there no visible damages at the safety elements?
- Do the belts not rasp on other parts?

3. Checking the cables and supply lines

- Check the cables visibly for damages.
- Check the entire moving range of PAN and TILT, if the cables are not **broken, bended, stretched** or **damaged** anyhow.
- Are the cables not porous?

4. Checking the screw connections of the lamp fixings

- Check all clamping bolts if they are well fixed.

Following maintenance is **recommended**:

- Remove dust, especially on electrical parts. Electronic is very sensitive for dust and reacts with strange behaviour!
- Keep focus spindle inside the lamp turnable with *Loctite 8151*™.
- Fatten the potentiometer-toothwheel with temperature stable bearing fat.
Recommended: Use a brush to put the fat on it. Do not use too much. A few grams are enough.

Error messages

Only Licht-Technik trained personal is authorised to work on the motoryoke!

Error	Description	Possible reasons	Possible solutions
E20	DMX-Signal missing	Defective supply line (data power) to the motoryoke. (Pin2 and/or 3 broken) Defective supply line to the splitbox (Pin2 and/or 3 broken)	Check the DMX-signal cables. The LED „DMX ok“ at the splitbox must light DMX mixing panel not ready
E21	DMX-Signal interchanged	Defective supply line (data power) to the motoryoke. (Pin2 and/or 3 interchanged) Defective supply line to the splitbox (Pin2 and/or 3 interchanged)	Check the DMX-signal cables. The LED „DMX ok“ at the splitbox must light.
E23	DMX-noise	Too much cable length. Bad signal quality.	Check the DMX signal cables. Check the DMX-connections Use a terminating resistor
E28	EEPROM error. Program memory test failed	Aging Electrostatic charge	No solutions. Inform Licht-Technik
E29	RAM Error. Working memory test failed	Aging Electrostatic charge	No solutions. Inform Licht-Technik
E30	PAN-motor blocked	Cable to motor broken	Check connections/solder joints
E31	TILT-motor blocked	Cable to potentiometer broken	Check connections/solder joints
		Potentiometer defective	Change potentiometer
		Motor defective	Change motor
		Yoke is blocked mechanically	Remove blocking
		A foreign object is in/at the drive	Remove object
		Motor/potentiometer connections interchanged when replaced.	Check connections
			Inform Licht-Technik
E32	Lamp rotation blocked	Lamp rotation axis blocked	Check easy movement of the axis.
		Moving range in P14, P15 not correct	Set correct values
		Focus motor defective	Change motor
		Focus potentiometer defective	Change potentiometer
		Connection cable to Focus module defective	Check connections and possible short circuits
			Inform Licht-Technik
E33	Barndoor 1blocked	Barndoor mechanically blocked	Remove blocking
E34	Barndoor 2blocked	Axis blocked	Check easy movement of the axis.
E35	Barndoor 3blocked		
E36	Barndoor 4blocked	Moving range in P16 - P23 not correct	Set correct values
		Barndoor motor defective	Change motor
		Barndoor potentiometer defective	Change potentiometer
		Connection cable to barndoor module defective	Check connections and possible short circuits
			Inform Licht-Technik

Malfunctions

- No display after power up.

The device houses a slow-blow fuse for feeble currents of 6.30 A protecting the equipment of wrong polarities on the supply line. When the fuse is blown, cable and polarity have absolutely be checked (pin1 = 0 V, pin 4 = +24V).

- No error message but motoryoke does not move

- Check DMX-addressing (*P01, DMX-Address motoryoke, page 18*).
- Is the speed-channel not set to 0? Check it with the DMX-tester in *P30, page 38*

- No error message but the lamp rotation does not move

- Is the module switched on? Check *P02, Focus module ON/OFF, page 19*.
- Check the incoming DMX-values with the DMX-tester in *P30, page 38*. The rotation-channel is start-channel (*P01, page 18*) + 4 or 5 (depends on *P27, page 36*). Refer to *DMX-channels motoryoke, page 17*.

- No error message but the barndoor does not move

- Is the barndoor-module switched on? Check *P03, Barndoor module ON/OFF, page 20*
- Is the barndoor-cable well connected?
- Check the incoming DMX-values with the DMX-tester in *P30, page 38*. The DMX-channels for the barndoor can be checked with *DMX-channels motoryoke, page 17*.

Warranty

The warranty for our products is 2 years. It comprises any repair of failures – free of charge – which can be proved to result from defects of fabrication.

Warranty expires when:

- the device was modified or attempted to be repaired
- damages were caused by the intervention of foreign persons
- damages are due to non-compliance with the operating instructions
- the device was connected to an incorrect voltage or incorrect type of current
- the device was incorrectly operated or when damages were caused by negligent handling or misuse

All maintenance and servicing works related to the product must be carried out by the company *Licht-Technik*. *Licht-Technik* shall not assume any liability for losses or damages of any kind being the results of inexpert servicing.

Further information

This document and the information contained therein are subject to copyright and neither the whole nor any part of it may, and this is also valid for the described product, be reproduced, copied or recorded in any form without the prior written authorization of *Licht-Technik Vertriebs GmbH*.

The products of *Licht-Technik GmbH* are subject to constant development. Therefore *Licht-Technik* reserves the right to modify components, motors and also technical specifications any time and without prior notice.

EC Declaration of Conformity

1. **Type of device/product** Motorbügel Studio 2000, Motorbügel Rohr
2. **Name and address of manufacturer** Licht-Technik Vertriebs GmbH
Osterwaldstraße 9-10
80805 München
3. **The manufacturer is responsible for this declaration**
4. **Item of declaration** **MB-STA, MB-STB, MB-STC, MB-R, MB-L7,
MB-L10, MB-D1, MB-S60, MT-200-03-V2, MT-250,
MT-300-03, MT-350, MT-430, MT-500, MB-F-12-V2,
MB-F-13-V1, MB-F-13-V2, MB-F-13-V3, MB-F-15, MB-S60**
5. **The described item is conform to the following guidelines/regulations**

RICHTLINIE 2014/30/EU DES EUROPÄISCHEN PARLAMENTS UND DES RATES vom 26. Februar 2014 zur Harmonisierung der Rechtsvorschriften der Mitgliedstaaten über die elektromagnetische Verträglichkeit

RICHTLINIE 2006/42/EU DES EUROPÄISCHEN PARLAMENTS UND DES RATES vom 17. Mai 2006 über Maschinen und zur Änderung der Richtlinie 95/16/EG (Neufassung)

RICHTLINIE 2011/65/EU DES EUROPÄISCHEN PARLAMENTS UND DES RATES vom 8. Juni 2011 zur Beschränkung der Verwendung bestimmter gefährlicher Stoffe in Elektro- und Elektronikgeräten
6. **Applied and conform to harmonized standards in particular**

DIN EN 55015; VDE 0875-15-1:2016-04 - Grenzwerte und Messverfahren für Funkstörungen von elektrischen Beleuchtungseinrichtungen und ähnlichen Elektrogeräten (CISPR 15:2013 + IS1:2013 + IS2:2013 + A1:2015); Deutsche Fassung EN 55015:2013 + A1:2015

DIN EN 61547; VDE 0875-15-2:2010-03 Einrichtungen für allgemeine Beleuchtungszwecke – EMV-Störfestigkeitsanforderungen (IEC 61547:2009); Deutsche Fassung EN 61547:2009

DIN EN 60204-1:2014-10; VDE 0113-1:2014-10 Sicherheit von Maschinen - Elektrische Ausrüstung von Maschinen - Teil 1: Allgemeine Anforderungen (IEC 44/709/CDV:2014); Deutsche Fassung EN 60204-1:2014
7. **A test report is available from company Licht-Technik Vertriebs GmbH**
8. **This declaration is invalid if the device is changed technically and/or unintended use.**

Signed for Licht-Technik Vertriebs GmbH

Place and date of description München 18.9.2017



Uwe Hagenbach (Geschäftsführer)

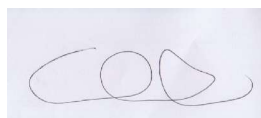

Bernhard Grill (Geschäftsführer)