



Stargate MT-XXX-02 Software Version 1.0

Functional description

Fabrication and marketing
Licht-Technik Vertriebs GmbH
Hagenbach & Grill
Osterwaldstr. 9-10 80805 München
Tel. 089-360528-0 Fax 089-360528-30
Last updated on: 26/10/10 Rev.: 1.0

Caution! Operate the device only after having read and **understood** operating instructions!

Table of content

Introduction.....	4
Appropriate use.....	4
The Licht-Technik motorised barndoor.....	5
Identification.....	6
Safety- and operating instructions.....	7
Disposal.....	10
The DMX-standard in lighting.....	11
Cabling.....	12
Getting started.....	13
User interface.....	14
Display lighting ON/OFF.....	14
DMX channel barndoor.....	15
Automove function.....	15
P01 DMX-address barndoor.....	16
P07 Barndoor rotation middle position.....	17
P16 Barndoor 1 closed position.....	18
P18 Barndoor 2 closed position.....	19
P20 Barndoor 3 closed position.....	20
P22 Barndoor 4 closed position.....	21
P23 Barndoor 1..4 moving range.....	22
P25 Barndoor rotation moving range.....	23
P28 Barndoor automove function ON/OFF.....	24
P30 Displaying the DMX-value.....	25
P32 Selecting the user language.....	26
P35 Unit number Netspider.....	27
P39 Interchanging barndoor rotation moving direction.....	28
Factory presettings.....	29
Technical Data.....	30
Maintenance.....	31
Error messages.....	32
Malfunctions.....	33
Warranty.....	33
Further information.....	33
Declaration of conformity.....	34

Introduction

Dear customer,
thank you for buying this product. You got a product which is state of the art. It complies with national and european standards (electromagnetic compliance 2004/108/EG). The conformity was proven, the corresponding declaration and documents are deposited at the manufacturer. To sustain this status and ensure a safe operation, the user must observe this manual!

Appropriate use

The motorised barndoor is mounted in front of a headlight to influence the light. In particular, the sides of the lightbeam can be covered.

An outdoor use can take place only conditionally, because the housing is not waterproof. The contact of water must be avoided in any circumstances. For cleaning of the housing, a dry, lint-free cleaning rag can be used. The use of cleanser should be omitted. An other usage as described above can lead to damage and, in addition, the risk of short circuit, fire, injury and death exists. The whole product must not be modified and reconstructed. The housing must not be opened.

The safety and operating instructions must be observed in any circumstances.

The Licht-Technik motorised barndoor

The Licht-Technik barndoor is a **versatile, precise** and **powerful** tool for light control.

Since 1991 the company Licht-Technik designs headlight accessories for film, TV and theatre houses. We only use the best components of the world-wide leading companies. The **aluminium** housings are characterised by high stability, high quality and low dead weight. The devices are manufactured on own **CNC** controlled machines and can guarantee a continuously **high quality standard**. Noise is optimised sequentially and provides thereby for extremely quiet positioning of the headlights. We manufacture the Motoryokes in cooperation with our customers for the desired sizes.

The control is made by the **DMX-512 USITT**-interface. The four leafs and the rotation can be controlled.

The built in **16-Bit Processor** provides a high throughput of the computer, quick positioning and uncomplicated handling. Even when triggering several motoryokes the precise control system provides a high synchrony of the movement.

Because of the absolute value devices in all axis, the device does not perform any **initialisation runs** after power up.

The **self-locking** drives provide a stable position in power off state.

The motoryoke has a mechanical and electronical **torque delimitation** on the PAN and TILT axle. The mechanical torque limitation is realised with a friction **clutch** and prevents a personal injury of people working on the yoke. Furthermore the drives and gearboxes will not be damaged when moving the yoke in case of power off.

The **electronical torque delimitation** switches off the motors in case of blocking (e.g. blocking because of moving onto a wall or decoration). The display shows an appropriate error message.

The **automove** function avoids impossible positions of the four leafs (e.g. leaf 4 to 90° and leaf 1 closed). Furthermore, the complete closing (homing) and opening is internally controlled leaf-by-leaf.

The lighted **LCD display** (the light can be switched off) leads the user in plain text instructions through the various programming steps. The instructions are available either in english or german language.

The device has a mechanical and electronical **torque delimitation** at the leaf axles and a electronical torque delimitation at the rotation axle. The mechanical torque limitation is realised with a friction **clutch** and prevents a personal injury of people working on the barndoor. Furthermore the drives and gearboxes will not be damaged when moving the yoke in case of power off.

The **electronical torque delimitation** switches off the motors in case of blocking (e.g. moving onto a wall or decoration). The display shows an appropriate error message.

Identification

The devices are **identified** by a number on the identification plate as follows:

MT – XXX -02

MT = **Motortor** (=Motorised barndoor). All types

XXX = Diameter, from 200mm to 500mm

Safety- and operating instructions

Never exceed the maximal possible **load of the mounting point**. (Rigg etc.)

Make sure that the **maximum load** of the fastening spigot will not be exceeded.

Never exceed the **maximum load** of the motoryoke (if used). It is written on the identification plate.

The barndoor must only be operated in the **operating position** provided for this purpose. Operating position is LCD-display on the bottom side.

Make sure that all fixtures of the yoke are **tightened**. Observe the torque of the screws or nuts.

Fast the headlight and all accessories like color changer, dimmer shutter and (motorised) barndoor with **safety belts**. See picture:

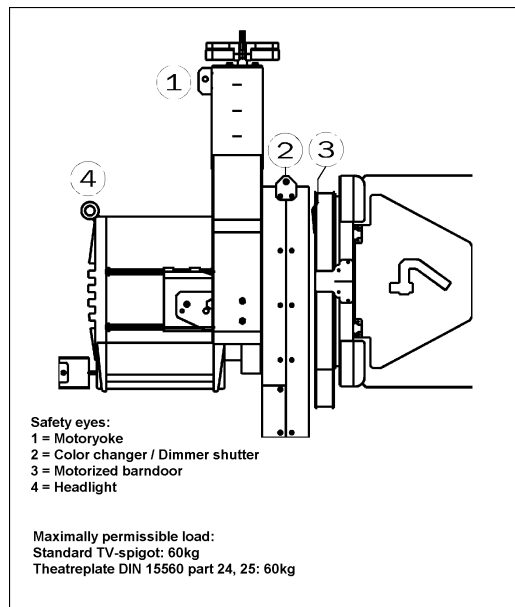

Make sure that the safety belts have the right diameter. For weights up to 60 kg a belt of 10mm diameter is necessary for the one way method and a belt of 6mm is necessary for the two way method.

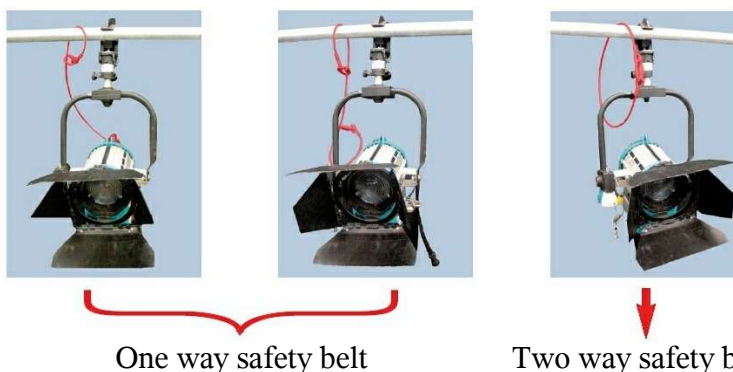

The user is **responsible** for the correct use of safety parts!

Make sure that all parts which are mounted on the headlight are right **tightened**.

Lever forces must not have an effect on the Motoryoke. This means that the installed motoryoke must not be **shifted** or **bended**! It is also forbidden when fastening spigot is opened.

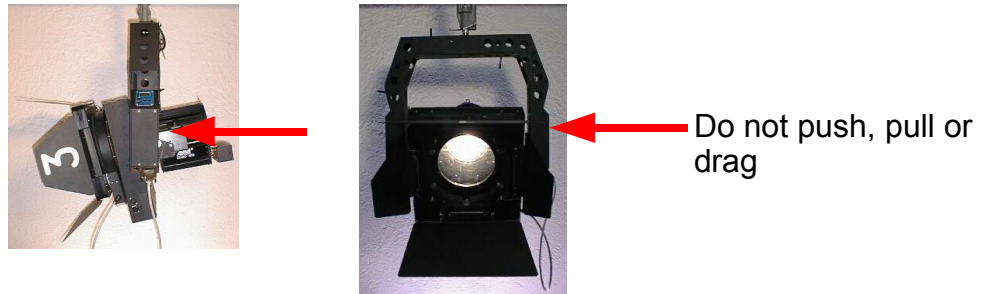

That applies also to the **transport**. It is absolutely forbidden to hang up the yoke on its spigot when transported!

If you want to use a transport **carriage**, it must be certified by Licht-Technik!

A safety device that was **once loaded** or is visibly damaged **must not** be used anymore!

When working on the device, it must be **switched off** or the power line must be interrupted. Make sure that the motorised barndoor cannot be moved by the control panel.

The operator must make sure that **no person** is in the swivelling range of the motoryoke. Inform your coworker and colleagues that the motoryoke is behaving like a work robot. When the position is changed at the control panel the device is trying to move on this position. There is the danger of being bruised and get frightened.

Admissible ambient **temperature**: 0..45 degree Celsius.

The device must not be **lit directly**

Check the whole swivelling range of the headlight. The manufacturers of the lamps specify **minimum permissible distances** to inflammable materials. Make sure that these distances are attended in every position of the lamp.

The manufacturers of the lamps specify maximum **inclination**. HMI headlights are not allowed to operate with the ignition electronic on the top.

The device must be kept **dry**. In case of water condensation a waiting period of up to 2 hours is necessary until acclimatisation is reached.

Power supply of Licht-Technik Motoryokes via the DataPower input must only be realised via power supplies **authorised** by us (safe electrical separation from the mains).

If motoryokes are used, the complete system is **balanced** in the factory with all (optional) additional devices (color changer and/or dimmer shutter and/or barndoor and/or Focus). The motoryoke must only be operated with this additional devices to keep the balance, otherwise the motor and/or gearbox can be damaged.

Damages caused by **non observance** of this manual the warranty claim will expire!

Observe all **hints** in this manual!

If you have problems to **get started** with this product, please contact company Licht-Technik.

This product is not a childrens toy. **Keep it away from children!**

Make sure that nothing falls on the housing and keep it dry.

The **accidental prevention regulations** must be observed! The usage in educational establishments must be observed by teachers.

When it has to be assumed that a **safe operation** is no longer possible, the equipment must be switched off immediately and be **secured against unintended** operation.

This is the case when

- the equipment shows visible damages
- the equipment is no longer functional
- parts of the equipment are loose or slackened
- connecting lines show visible damages

Attention:

Before starting the equipment the user must check the usefulness of the device for its intended use.

We reject every **liability**:

- Damages and indirect damages or every kind of costs, which result from the use of Licht-Technik products.
- Any damages which result from negligence, improper use and setup, wrong setting into operation and use, ignoring of valid safety regulations, unsuitable use and bad maintenance of Licht-Technik products.

Disposal

No longer required packaging and packaging aids are recyclable and should be given up to collecting points.

Used up batteries and accus are not for household garbage. These must be brought to recycling stations. Information about recycling stations are available at your responsible municipal administration.

Attention!

This product with all electrical and electronical components must not be disposed in the household garbage! For this kind of products a separate disposal system is defined by law!

Information for disposal by the user in the european union:

Used electrical and electronical devices must be disposed separately to ensure a environment friendly recycling. These products must be given up to responsible collecting points. The disposal is free of charge for the user. Please enquire at your local administration where you can give up this product for professional recycling. If your product is equipped with batteries or accus, please remove them before disposal and give them up separately (see above).

Information for disposal by the user outside the european union:

If you want to dispose this product, please contact your local responsible municipal administration for environment friendly recycling.

By giving up the product to responsible collecting points you support a professional recycling and make a significant contribution for protecting the environment and human health.

The DMX-standard in lighting

Because of many problems with **analogue** data-signals from the control panels to the dimmers the DMX-standard was developed in 1990. DMX only needs **two** wires to control up to 512 dimmers digitally. On the other hand, the old analogue method needs one wire for every dimmer. Many kilometers of cable have been saved.

The DMX-signal is based on the industrial **RS485** interface. It is designed for maximum lengths up to 1200m. Normally this length is under condition in theatre or studio **not possible** (strong electrical fields because of the HMI lamps). As a result of internal tests we recommend a maximum length of **200m** (only DMX line, 5pin). On every DMX transmitter a maximum of 32 DMX receiver can be connected. All devices must be connected in a **row** (cabling from A to B, from B to C, from C to D etc.). The last device in such a row must be terminated with a resistor (470 Ohm). If more than 32 devices should be connected a booster or **splitbox** must be inserted.

A **splitbox** is a device with one DMX input and several DMX outputs. The signal is refreshed. Thus it is possible to use different DMX lines.

The reliability of data transmission was increased because of using DMX. One of the greatest advantages is universally usefulness. Now devices from different manufacturers can be controlled by every control panel.

Cabling

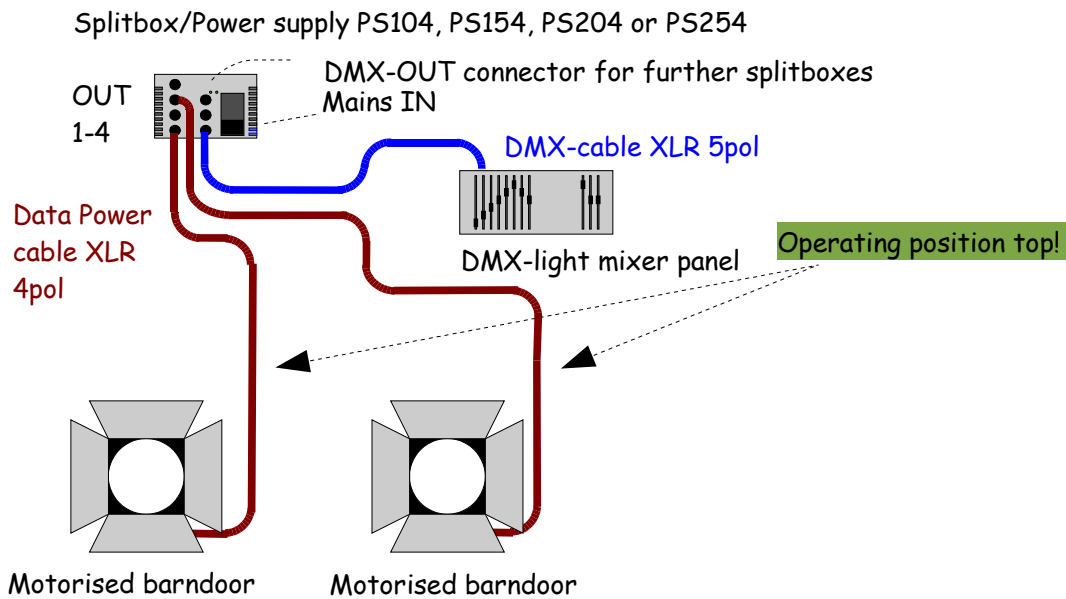

For pinout of cables refer to *technical data, page 30*

Make sure that the connected power does **not exceed** the maximum power output of the power supply. Keep other devices like shutters or color changers in mind which are possibly connected. The maximum required power per device is always given on the identification plate. All devices together, which are connected to the power supply, must not exceed the power output of the power supply.

The device can also be wired via daisy chain after a color changer and/or dimmer shutter.

The last device in a row should be terminated with a resistor (470 Ohm). The total length of a 4pin cable must not exceed **80m**.

Getting started

Setup the device on the desired place **according** to the *operating and safety instructions*, page 7.

After that **connect** the device like illustrated in *cabling*, page 12.

Switch on the power supply. During testing its internal program memory and the control it shows "init" in the display. After that the barndoor is moving to the programmed position. The second display line shows the DMX-address and value of the first leaf.

Caution!

Make sure that the motoryoke is not moved by the **control panel** before programming. Otherwise the motoryoke will move during programming if the position is changed at the panel!

Further programming possibilities like DMX addressing are specified on the following pages.

Tip:

When the motoryoke is in **programming mode**, all moving orders are ignored. Make sure that the device is in operating mode after programming, otherwise it will not move! Press two times the OK key for leaving the programming mode!

User interface

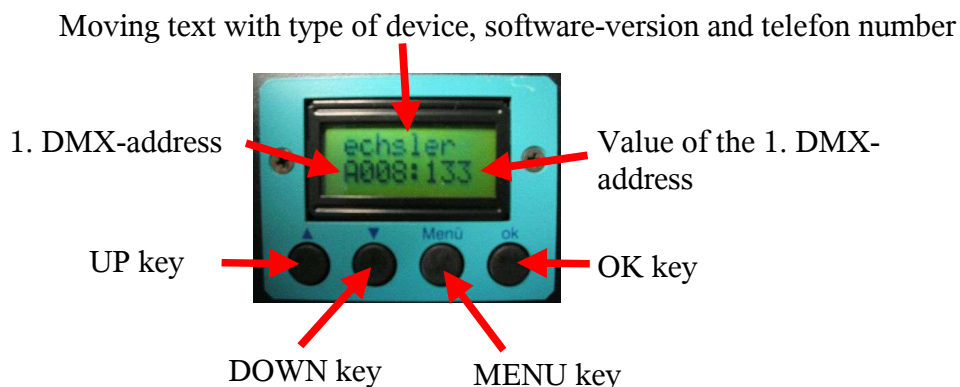

In normal operating mode the **LCD-display** indicates different information. The first line shows the Licht-Technik moving text with details on type of device, software version and telephone number. The second line indicates the first DMX-address and its incoming value (8-Bit, 0..255). For the motorised barndoor, this address represents the value of the first leaf.

With the four **keys** the device can be programmed. Instruction for this, is on the following pages.

Display lighting ON/OFF

In normal operation the LCD backlight is switched off to avoid a disturbing light. Only if an error occurs or during programming the light will be switched on automatically. The user can also switch it on manually to see what is indicated.

Condition: Device is on working level

Operation:



depress. Display lighting **ON**



depress again. Display lighting **OFF**

DMX channel barndoor

The following chapters require the **DMX-channel assignment** of the motorised barndoor.

Channel	Function
Start channel	Leaf 1
Start channel + 1	Leaf 2
Start channel + 2	Leaf 3
Start channel + 3	Leaf 4
Start channel + 4	Barndoor rotation

The **first** address is programmed in menu *P01, DMX-address barndoor, page 16*. All other **follow** this first address.

Example:

Menu P01 is programmed to address 234. Consequently:

Leaf 1: Address 234

Leaf 2: Address 235

Leaf 3: Address 236

Leaf 4: Address 237

Rotation: Address 238

Automove function

The automove function prevents from crashing the leafs. This can be the case when the DMX values of all leafs are set to 0% in the same time. With this function a sorted closing or opening is possible. Furthermore a collision can be avoided with adverse control values. For example, when barndoor 4 is controlled to 90° and barndoor 1 should be in closed position.

This function is only active when the DMX values of **two** or **more** leafs are changing within one second. If only one DMX value is changed, the corresponding leaf will be positioned without concerning the position of the other leafs. With that algorithm, it is possible to program small slots of light. For example leaf 3 and 4 can be positioned to 90° and leaf 1 and 2 can be moved adjacent to 3 and 4.

P01 DMX-address barndoor

At this point the **first DMX-address** of the device can be adapted to the desired DMX-address of the light mixing panel. This address represents the PAN-DMX-address. All other addresses follow this address. Refer to *DMX-channels motoryoke, page 15*.

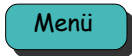

Range of values: Address 1..508

Operation:

 depress You are now on menu level. The last adjusted menu point is displayed, e.g.:
`MENU P01: BARNDOOR ROTATION MIDDLE
POSITION`

  depress ... until `MENÜ P01` is displayed.

 depress The second line displays the currently adjusted value.

  depress Adjust the desired DMX address.

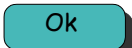
 depress You are back on menu level.

 depress The equipment is ready for operation.



P07 Barndoor rotation middle position

At this point the **middle position** of the barndoor rotation can be programmed. This is the position for 50% DMX.



Range of values: 10..1000 (value of the absolute value device)

Operation:

 depress You are now on menu level. The last adjusted menu point is displayed, e.g.:
`MENU P01: DMX ADDRESS BARNDOOR`

  depress ... until `MENÜ P07` is displayed.

 depress The second line displays the currently adjusted value.

  depress If you depress once UP or DOWN, the device moves to the currently programmed and indicated value. Wait until the rotation axle does not move any more. After that, adjust the position. The optimal position is when barndoor 1 is on top and absolutely horizontally.

 depress You are back on menu level.

 depress The equipment is ready for operation.

P16 Barndoor 1 closed position





At this point the **barndoor 1 position for 0% DMX-value** can be set.

Guideline!

You should adjust the barndoors in this order: 4 3 2 1 !
Before starting, open all leafs (100%)

Range of values: 10..1000 units (value of the absolute value device)

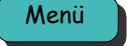
Operation:

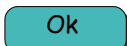
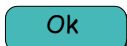
-  depress You are now on menu level. The last adjusted menu point is displayed, e.g.:
`MENU P01: DMX ADDRESS BARNDOOR`
-   depress ... until `MENÜ P16` is displayed.
-  depress The second line displays the currently adjusted value.
-   depress If you depress once UP or DOWN, the device moves to the currently programmed and indicated value. Wait until the leaf does not move any more. After that, adjust the position. The optimal position is when the leaf has a little gap of around 1mm.
-  depress You are back on menu level.
-  depress The equipment is ready for operation.

P18 Barndoor 2 closed position





At this point the **barndoor 2 position for 0% DMX-value** can be set.

Guideline!

You should adjust the barndoors in this order: 4 3 2 1 !
Before starting, open all leafs (100%)

Range of values: 10..1000 units (value of the absolute value device)

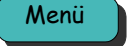
Operation:

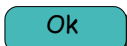
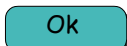
-  depress You are now on menu level. The last adjusted menu point is displayed, e.g.:
`MENU P01: DMX ADDRESS BARNDOOR`
-   depress ... until `MENÜ P18` is displayed.
-  depress The second line displays the currently adjusted value.
-   depress If you depress once UP or DOWN, the device moves to the currently programmed and indicated value. Wait until the leaf does not move any more. After that, adjust the position. The optimal position is when the leaf has a little gap of around 1mm.
-  depress You are back on menu level.
-  depress The equipment is ready for operation.

P20 Barndoor 3 closed position





At this point the **barndoor 3 position for 0% DMX-value** can be set.

Guideline!

You should adjust the barndoors in this order: 4 3 2 1 !
Before starting, open all leafs (100%)

Range of values: 10..1000 units (value of the absolute value device)

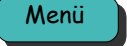
Operation:

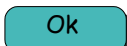
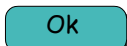
-  depress You are now on menu level. The last adjusted menu point is displayed, e.g.:
`MENU P01: DMX ADDRESS BARNDOOR`
-   depress ... until `MENÜ P20` is displayed.
-  depress The second line displays the currently adjusted value.
-   depress If you depress once UP or DOWN, the device moves to the currently programmed and indicated value. Wait until the leaf does not move any more. After that, adjust the position. The optimal position is when the leaf has a little gap of around 1mm.
-  depress You are back on menu level.
-  depress The equipment is ready for operation.

P22 Barndoor 4 closed position







At this point the **barndoor 4 position for 0% DMX-value** can be set.

Guideline!

You should adjust the barndoors in this order: 4 3 2 1 !
Before starting, open all leafs (100%)

Range of values: 10..1000 units (value of the absolute value device)

Operation:

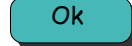





-  depress You are now on the menu level. The last adjusted menu point is displayed, e.g.:
`MENU P01: DMX ADDRESS BARNDOOR`
-   depress ... until `MENÜ P22` is displayed.
-  depress The second line displays the currently adjusted value.
-   depress If you depress once UP or DOWN, the device moves to the currently programmed and indicated value. Wait until the leaf does not move any more. After that, adjust the position. The optimal position is when the leaf has a little gap of around 1mm.
-  depress You are back on menu level.
-  depress The equipment is ready for operation.

P23 Barndoor 1..4 moving range

With this function the **opening angle** of all barndoors can be set. This adjustment is for all 4 barndoors.

Range of values: 90..130 degrees

Operation:

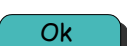
-  depress You are now on menu level. The last adjusted menu point is displayed, e.g.:
`MENU P01: DMX ADDRESS BARNDOOR`
-   depress ... until `MENÜ P23` is displayed.
-  depress The second line displays the currently adjusted value.
-   depress Adjust the desired moving range
-  depress You are back on menu level.
-  depress The equipment is ready for operation.









P25 Barndoor rotation moving range

With this function the **moving range of the barndoor rotation** can be set. The rotation angle has as reference point the middle position of the barndoor rotation, described in *P07 Barndoor rotation middle position, page 17*. This is the 50% DMX position. If this menu is programmed to 90°, the barndoor rotation moves 90° to the left **and** 90° to right from the middle position.

Range of values: 0..92 degrees

Recommended value: 90°

Operation:

-  depress You are now on menu level. The last adjusted menu point is displayed, e.g.:
`MENU P01: DMX ADDRESS BARNDOOR`
-   depress ... until `MENÜ P25` is displayed.
-  depress The second line displays the currently adjusted value.
-   depress Adjust the desired moving range
-  depress You are back on menu level.
-  depress The equipment is ready for operation.

P28 Barndoor automove function ON/OFF

In this menu the automove **function** can be switched ON or OFF.

If **2 or more** barndoors are moved (opened or closed makes no difference) at once, the control unit can calculate the right moving order to avoid crashes (if this menu is set to 1).

When closing, the barndoors are moved in this order: 4, 3, 2, 1.



When opening, the barndoors are move in the inverse order: 1, 2, 3, 4.

But: If only one barndoor is moved a crash can occur! E.g.: It will crash if all barndoors closed and only moving number 1!



Range of values: 0: Automove function **off**
1: Automove function **on**

Operation:

-  depress You are now on menu level. The last adjusted menu point is displayed, e.g.:
`MENU P01: DMX ADDRESS BARNDOOR`

-   depress ... until `MENÜ P28` is displayed.

-  depress The second line displays the currently adjusted value.

-   depress Adjust the desired value.

-  depress You are back on menu level.

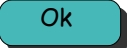
-  depress The equipment is ready for operation.



P30 Displaying the DMX-value

This function assists you in **checking** the values transmitted by the light mixer panel. At this point you can quickly detect whether the device is triggered with the **correct** values. It is possible to check all 512 DMX channels. Note that the value of the address programmed in this menu will be indicated in normal operation. After power up the programmed address in menu P01 (page 16) will be displayed.



Range of values: Address 1..512

Operation:

 depress You are now on menu level. The last adjusted menu point is displayed, e.g.:
`M E N U P 0 1 : D M X A D D R E S S B A R N D O O R`

  depress ... until `M E N U P 3 0` is displayed.

 depress The second line displays the currently adjusted value.

  depress Adjust the desired address.

 depress You are back on menu level.

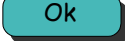
 depress The equipment is ready for operation.



P35 Unit number Netspider

With this function you can set the **unit number** for Netspider systems.



Range of values: 0..9999

Operation:

 depress You are now on menu level. The last adjusted menu point is displayed, e.g.:
`MENU P01: DMX ADDRESS BARNDOOR`

  depress ... until `MENU P35` is displayed.

 depress The second line displays the currently adjusted value.

  depress Adjust the desired unit number.

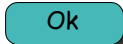
 depress You are back on menu level.

 depress The equipment is ready for operation.

P39 Interchanging barndoor rotation moving direction



With this function the **barndoor rotation moving direction** can be set.

Range of values: 0 = normal (standard)
1 = reverse direction



Recommended value: 0

Operation:

 depress You are now on menu level. The last adjusted menu point is displayed, e.g.:
`MENU P01: DMX ADDRESS BARNDOOR`

  depress ... until `MENU P39` is displayed.

 depress The second line displays the currently adjusted value.

  depress Adjust the desired direction.

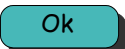
 depress You are back on menu level.

 depress The equipment is ready for operation.

Factory presettings

Menu	Description	Value
P01	DMX-address motorized barndoor	1
P07	Barndoor rotation middle position	individual
P16	Barndoor 1 0-position	individual
P18	Barndoor 2 0-position	individual
P20	Barndoor 3 0-position	individual
P22	Barndoor 4 0-position	individual
P23	Barndoor 1 2 3 4 max. opening position	105 degree
P25	Barndoor rotation moving range	90 degree
P28	Barndoor automove function ON/OFF	1 (ON)
P30	Show DMX	1
P32	User language	0 (german)
P39	Barndoor rotation moving direction	0 (standard)
P40	Unit number Netspider	0

Technical Data

Identification is described on page 6.

Weight and dimensions (Maximum opening angle, height from mounting plate):

Type	Length [cm]	Width [cm]	Height [cm]	Weight [kg]
Stargate MT-200-02	66	66	32	5,7
Stargate MT-250-02				
Stargate MT-300-02				
Stargate MT-350-02	81	81	27	7,5
Stargate MT-430-02	95	95	33	9,0
Stargate MT-500-02				

Connected loads: 24 V DC, max. 1,6 A, max. 40W

Fuse: 3,15 A slow blow

Pin assignment:

Data-Power-cable: 4pin XLR connector screened

Housing: Screen

PIN 1: 0 V (GND) min. cross section 0,75mm²

PIN 2: DMX-Data – min. cross section 0,25mm²

PIN 3: DMX-Data + min. cross section 0,25mm²

PIN 4: +24 V DC min. cross section 0,75mm²

The DMX wires must be twisted pair and shielded separately.

Maintenance

By regular maintenance a significant increase of **lifetime** and **reliability** can be achieved.

Regular maintenance increases safety significant!!

We recommend a maintenance **once** a year.

An **absolute must** are the following points:

1. Checking the safety elements

Check the safetybelts and further safetyelements like shackles, rings, lugs, chains:

- Are the belts not frayed out?
- Are the threads of the shackles okay? Are the screws of them easy to turn?
- Are there no visible damages at the safety elements?
- Do the belts not rasp on other parts?

2. Checking the cables and supply lines

- Check the cables visibly for damages.
- Check the entire moving range of PAN and TILT, if the cables are not **broken, bended, stretched** or **damaged** anyhow.
- Are the cables not porous?

3. Checking the screw connections of the lamp fixings

- Check all clamping bolts if they are well fixed.

Following maintenance is recommended:

- Remove dust, especially on electronical parts. Electronic is very sensitive for dust and reacts with strange behaviour!
- Keep focus spindle inside the lamp turnable with *Loctite 8151*™.
- Fatten the potentiometer-toothwheel with temperature stable bearing fat.
Recommended: Use a brush to put the fat on it. Do not use to much. A few grams are enough.

Error messages

Only Licht-Technik trained personal is authorised to work on the device!

Error	Description	Possible reasons	Possible solutions
E20	DMX-Signal missing	Defective supply line (data power) to the motoryoke. (Pin2 and/or 3 broken) Defective supply line to the splitbox (Pin2 and/or 3 broken)	Check the DMX-signal cables. The LED „DMX ok“ at the splitbox must light DMX mixing panel not ready
E21	DMX-Signal interchanged	Defective supply line (data power) to the motoryoke. (Pin2 and/or 3 interchanged) Defective supply line to the splitbox (Pin2 and/or 3 interchanged)	Check the DMX-signal cables. The LED „DMX ok“ at the splitbox must light.
E23	DMX-noise	Too much cable length. Bad signal quality.	Check the DMX signal cables. Check the DMX-connections Use a terminating resistor
E28	EEPROM error. Program memory test failed	Aging Electrostatic charge	No solutions. Inform Licht-Technik
E29	RAM Error. Working memory test failed	Aging Electrostatic charge	No solutions. Inform Licht-Technik
E33	Barndoor 1blocked	Barndoor mechanically blocked	Remove blocking
E34	Barndoor 2blocked	Axis blocked	Check easy movement of the axis.
E35	Barndoor 3blocked		
E36	Barndoor 4blocked	Moving range in P16 - P23 not correct	Set correct values
		Barndoor motor defective	Change motor
		Barndoor potentiometer defective	Change potentiometer
		Connection cable to barndoor module defective	Check connections and possible short circuits
			Inform Licht-Technik
Barndoor rotation			
E37	blocked	Barndoor rotation mechanically blocked	Remove blocking
		Moving range in P07/P25 not correct	Set correct values
		Barndoor rotation motor defective	Change motor
		Barndoor rotation potentiometer defective	Change potentiometer
		Connection cable to barndoor module defective	Check connections and possible short circuits
			Inform Licht-Technik

Malfunctions

- No display after power up.

The device houses a slow-blow fuse for feeble currents of 3.15 A protecting the equipment of wrong polarities on the supply line. When the fuse is blown, cable and polarity have absolutely be checked (pin1 = 0 V, pin 4 = +24V).

- No error message but device does not move

- Check DMX-addressing (*P01, DMX-Address barndoor, page 16*).

Warranty

The warranty for our products is 2 years. It comprises any repair of failures – free of charge – which can be proved to result from defects of fabrication.

Warranty expires when:

- the device was modified or attempted to be repaired
- damages were caused by the intervention of foreign persons
- damages are due to non-compliance with the operating instructions
- the device was connected to an incorrect voltage or incorrect type of current
- the device was incorrectly operated or when damages were caused by negligent handling or misuse

All maintenance and servicing works related to the product must be carried out by the company *Licht-Technik*. *Licht-Technik* shall not assume any liability for losses or damages of any kind being the results of inexperienced servicing.

Further information

This document and the information contained therein are subject to copyright and neither the whole nor any part of it may, and this is also valid for the described product, be reproduced, copied or recorded in any form without the prior written authorization of *Licht-Technik Vertriebs GmbH*.

The products of *Licht-Technik GmbH* are subject to constant development. Therefore *Licht-Technik* reserves the right to modify components, motors and also technical specifications any time and without prior notice.

Declaration of conformity

Manufacturer: Licht-Technik Vertriebs GmbH
Address: Osterwaldstraße 9-10
80805 München

declares that the product:

Name of product: **Motorised** barndoor
Type of product: Stargate MT-200-02, Stargate MT-250-02, Stargate MT-300-02
Stargate MT-350-02, Stargate MT-400-02, Stargate MT-430-02,
Stargate MT-500-02,

corresponds to the following specifications under strict observance of the installation instructions and technical specifications:

**Standard 2004/108/EG of the European Parliament and the council from
15. December 2004
for law provision adaptation of the member states concerning the electrical
compatibility and for
abrogation of standard 89/336/EEC.**

The device passed the test. A testreport is available at company Licht-Technik Vertriebs GmbH.

Munich, 6. July 2010

Uwe Hagenbach / Bernhard Grill
Managing directors