

Color Changer CC-Serie

Functional description Color Changer CC-Serie V2.16

Fabrication and Marketing
Licht-Technik
Hagenbach & Grill
Osterwaldstr. 9-10 80805 München
Tel. 089-360528-0 Fax 089-360528-30
E-Mail: info@Licht-Technik.com
last updated on: 28/09/09 Rev.: 2.17

Caution! Operate the device only after having read and **understood** the operating instructions!

Color Changer CC-series

The Color Changer of the CC-serie is a versatile Color Changer for event and par lambs.

This device is designed for exhibitions, light shows and events like that. In addition for use in theatre- and opera houses. The built in 16-Bit Microcontroller enables a quick and safe processing, intuitive user interface and uncomplicated operation.

The Color Changer is controlled by DMX512 (USITT 1990). The position of color tape, speed and also the fan intensity can be controlled by DMX to avoid disturbing noise during quiet scenes. In addition, the colors can be scrolled by keyboard. In this case, no DMX signal is required.

After putting in the color tape, the device automatically scans the frame positions. The positions of begin, end and color frames are detected by the device through the markers.

The Color string can be moved in frame by frame or linear mode. Frame by frame mode means that only full color frames can be selected. On the other hand, linear mode means that every position of the color string can be selected.

The built in potentiometer generates an absolute value of the tape position, thus no initialisation move must be performed.

The Marker and light sensor system provides an exact positioning of the color string.

As an optional extra „dark color mode“ is available, which moves the sensitive darker color frames from end to end in front of the light. The effect is a better heat distribution on the string. This requires a double length color frame. The device counts the dark colors as one frame.

For power supply we can offer the power supplies PS 104 and PS204 with integrated split box. An alternative are the *Licht-Technik* mixing panels with integrated power supply.

The lighted LCD display (light can be switched off) leads the user through the various program steps in plain language instructions. User instructions are available either in English or German language.

Table of content

Safety and operating instructions.....	5
User interface elements.....	6
Cabling.....	6
Dimensions of string and frames.....	8
Positioning of aluminium markers.....	10
Dimensions of strings of Licht-Technik color changers.....	12
Getting started.....	13
Putting in and scanning the tape	14
P01 DMX address position.....	18
P02 DMX address speed.....	19
P03 DMX address fan.....	20
P04 DMX-adress Move mode.....	21
P08 One address mode DMX-address.....	22
P09 Dark color mode speed (optional extra).....	23
P10 Dark colors (optional extra).....	24
P11 Move mode.....	25
P20 Internal speed.....	26
P22 Internal fan intensity.....	27
P24 Number of color frames.....	28
P26 Putting in the color string.....	29
P28 Handmode.....	30
P30 Show DMX.....	31
P32 User language.....	32
P35 Unit number (Netspider only).....	33
P51 Auto move (Demomode).....	34
Technical data.....	35
Factory presettings.....	36
Error messages / Failures.....	37
Warranty.....	38
Further information.....	38
Declaration of conformity.....	39

Safety and operating instructions

The color Changer must only be operated when being in the operating position for this purpose. Operating position is vertical with max. +/- 60 degree. But the motor unit must not be at the top position.

Admissible ambient temperature: 0 to +55 °C

The device is getting very hot because of the lamp. Let it cool down for at least one hour before touching.

The top and bottom vents must not be blocked or covered.

The equipment is designed to be used in dry and clean rooms.

The lamp must not shine outside the light hole. This means, the diameter of the light hole of the color changer must be the same or larger as the diameter of the lamp lens. For example: A 200mm color changer cannot be operated in front of a lamp with 300mm lens diameter.

The color changer must be kept dry. In case of water condensation, a waiting time of 2 hours is necessary until acclimatisation is reached.

Observe the maximum load of fastening spigots which will be increased by the additional weight of the color changer.

Make sure that the device is safe fixed at the lamp.

Use a safety belt.

Power supply via DATA Power input of the shutter must only be realized via power supplies authorized by us (electrical separation from the mains).

When it has to be assumed that a safe operation is no longer possible, the equipment must be switched off immediately and be secured against unintended operation.

This is the case when:

- the device shows visible damages
- the device is not functional
- parts of the device are loose or slackened
- connecting lines show visible damages

Prior to starting the equipment the user must check the usefulness of the device for its intended purpose. In particular, Licht-Technik shall decline any liability for damages of the equipment as well as for consequential damages resulting of the device being used inappropriately, of inexpert installation, incorrect starting, use and noncompliance with the valid safety regulations.

User interface elements

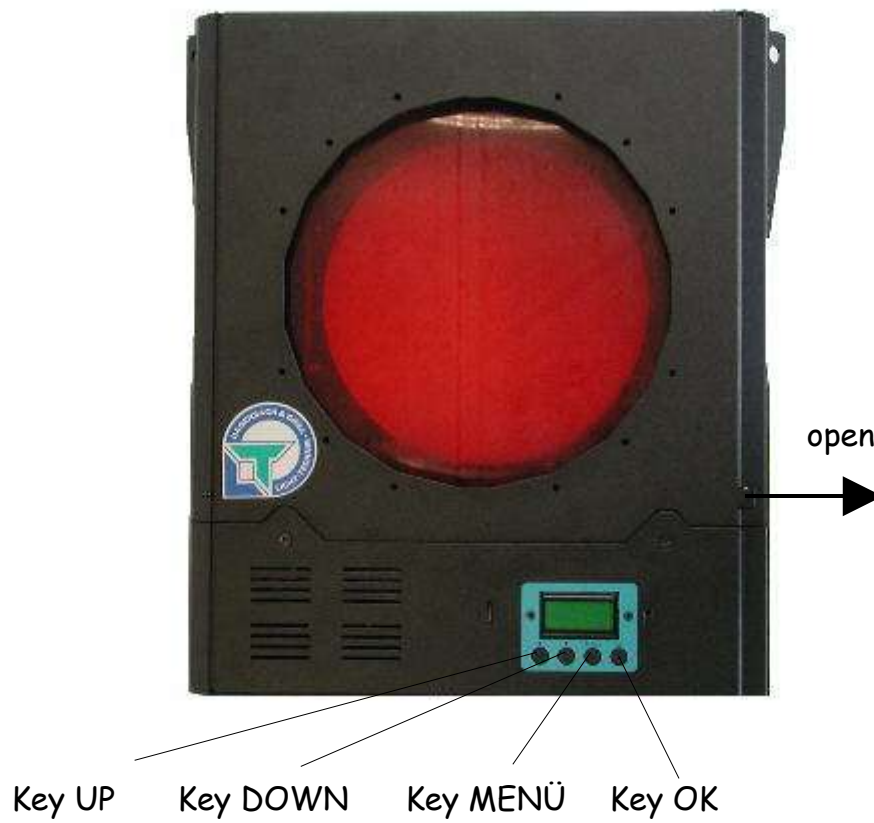

Cabling

The standardized DMX-Signal is based on industrie's RS485 Interface. It is designed for maximum lengths up to 1200m. This length is under condition in theatre or studio normally not possible. As a result of internal tests we recommend a maximum length of 200m (**only DMX, 5PIN**).

The maximum length of a Output (**Data Power, 4PIN**) must not exceed 80m because of the voltage drop.

Connect the light mixer panel and the Splitbox PS104/PS204 with a 5PIN XLR-DMX-cable. The splitbox is provided with a DMX out jack for connecting additional splitboxes. At each of the four DATA Power outputs for the devices a maximum of 4 Color Changers can be connected. However, the total number of Color Changers per splitbox must not exceed 16 Color Changer CC (PS204) or 8 Color Changer CC (PS104) respectively.

The last device of a serie should be connected with a terminating impedance (470 Ohm). It is plugged into the OUT connector of the last device of a row.

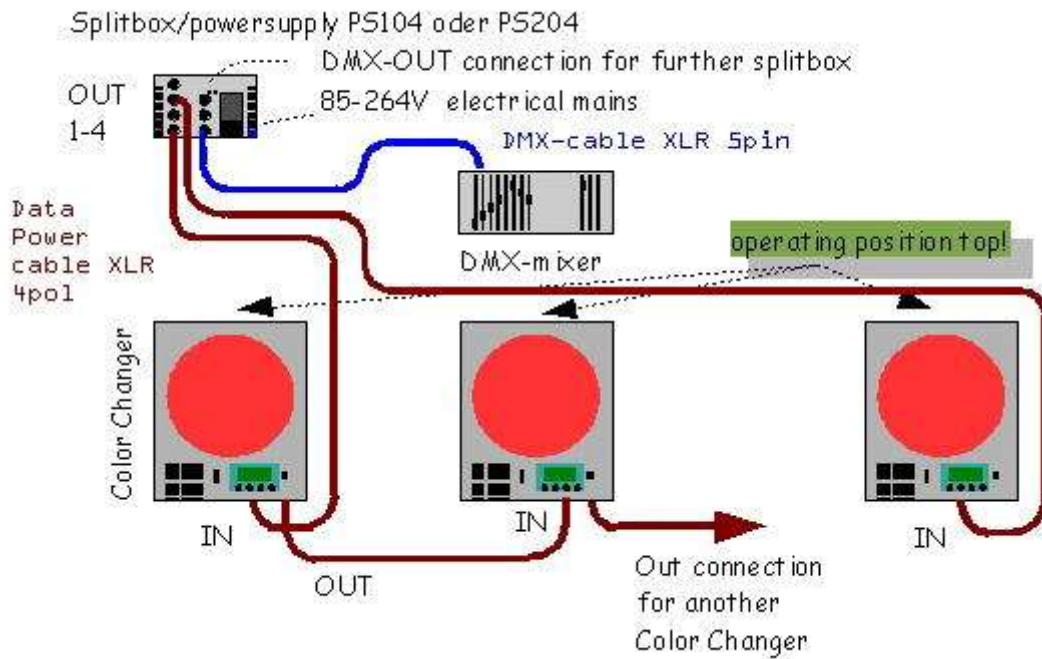

When operating with a *Licht-Technik* mixer panel it is not necessary to use a splitbox. These mixers come with a built in power supply.

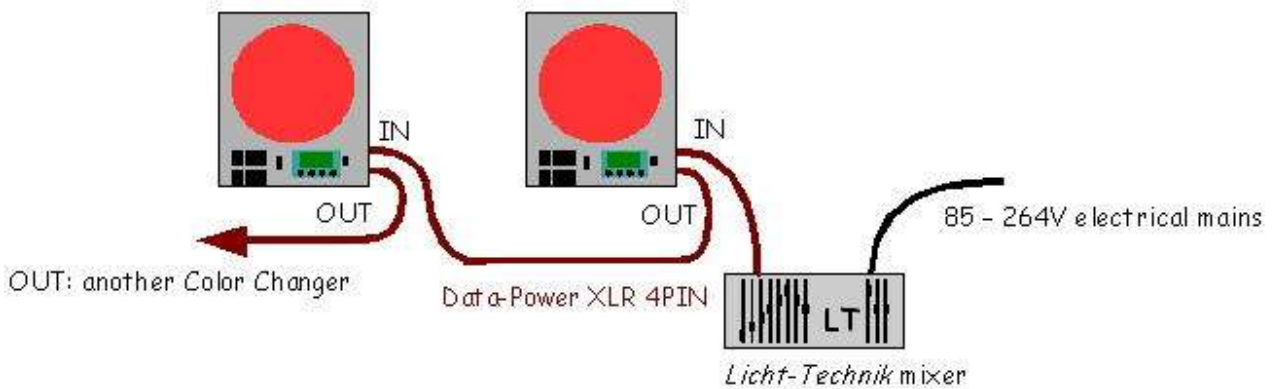

Maximum length of DATA Power cable is also 80m. The last device should be connected with a terminating impedance (470 Ohm). Total number of devices is 4.

If more devices should be connected, a PS104 (max. 8 Color Changer CC) or PS204 (max. 16 Color Changer CC) must be used. Cabling is like illustration on top of this page .

	<i>Licht-Technik</i> Mixer	PS104	PS204
Maximum number of CC per output	4	4	4
Maximum number of CC total	4	8	16
<i>Maximum number of Shutter Event depends on power supply</i>			

Dimensions of string and frames

We recommend filters of Rosco™ type Supergel©.

In addition, cut your gels to fit on the rolls in the same way like the gel is on original gel roll. You can avoid disturbing movement noise and a excessive wear of the foil.

Normal length

Normal length is the described frame or dark color frame size below.

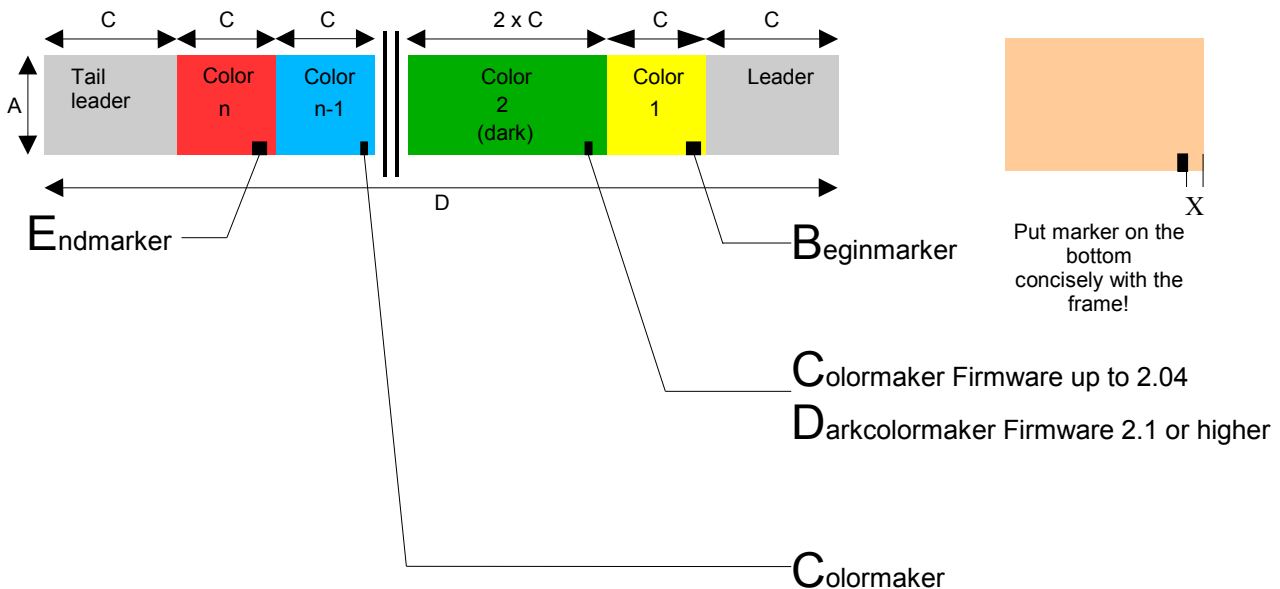

Type	height A (mm)	(tail-) leader B (mm)	color C (mm)	dark color 2 x C	tape D (mm)	max colors
CC175	192	240	240	480	7680	30
CC200	225	305	305	610	9760	30
CC270	276	370	370	740	9990	25
CC350	370	465	465	930	9300	18

Tapes with normal frame dimensions can have up to 30 colors (depends of the size of device). A dark color frame must be considered as two normal colors. For example: A string with the length of 20 colors and two dark colors has a maximum of 18 different color frames.

White diffusion proved itself extremely efficient as leader and tail-leader, since this type of material is fitting very closely and can compensate any inaccuracies resulting from the tape in procedure. We recommend to use a transparent adhesive tape with high temperature stability for this purpose.

The Darkcolormarker and the normal colormarker are identically in Firmware versions up to V2.04. The dark colors are set manually in menu P10.

With Firmware V2.1 and higher it is possible to the darkcolormarkers of the middle size (13x25mm, vertical).

The positioning of aluminium markers is described in the next chapter.

Other dimensions

Other dimensions are individually strings cut by the user. With these, the user can realize rainbow or sunrise effects for example.

The number of colors, the length of the frames and the position of the marker can be varied within the following restrictions:

- minimum number of markers: 2 (Begin and end).
- do not exceed the maximum number of markers (depends of the size of the device) inclusive begin- and endmarker.
- do not exceed the maximum tape length (length D, see table page)
- do not vary the height of the tape (length A, see table page)
- do not vary the (tail-)leader of the tape (length B, see table page)

Positioning of aluminium markers

The color changer can recognize the individual color positions with the light sensor and attached aluminium markers. This allows an exact positioning even when the foil strips have expanded because of heat.

The markers can be attached either when the string is inserted or not. You can stick them at the rear or front side of the tape. They have to consist of a light impermeable material (aluminium). They can also be ordered from our company.

Dimensions of the markers:

Type of marker	Dimensions (H x L)	
Begin- and Endmarker	25 x 25	
Color marker	6,5 x 25	vertically
Darkcolormarker, Firmware up to 2.04	6,5 x 25	vertically
Darkcolormarker, Firmware 2.1 and higher	13 x 25	vertically

Startmarker:

It is attached at the beginning of the first color frame. The middle of the Marker should be in the light sensor when the color frame is in middle position.

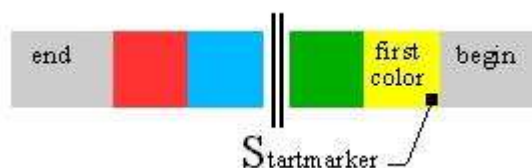

Endmarker:

It is placed at the beginning of the last color. The middle of the marker should be in the light sensor when the color frame is in middle position.

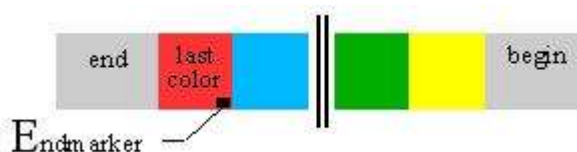

Colormarker:

It is placed upright at each color frame at the position shown below. It should be inside the light sensor when the color frame is in middle position.

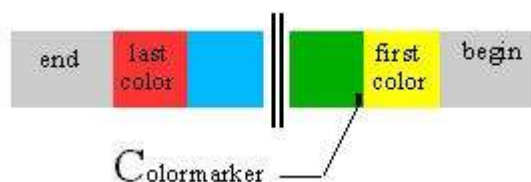

Dark color marker:

It is placed upright at each color frame at the position shown below. It should be inside the light sensor when the color frame is in middle position.
Note that the first and the last color must not be a dark color!

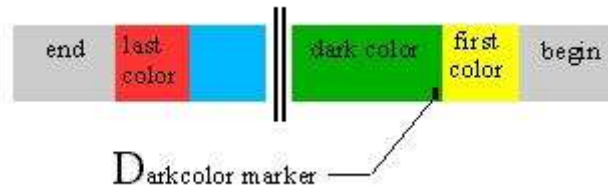

The position of the markers on the color frame:

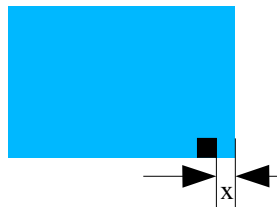

	Position x		
	CC 200	CC270	CC350
Startmarker	50	50	60
Endmarker	50	50	50
(Dark-) Colormarker	50	65	75

Put the marker concisely to the bottom of the frame!

Dimensions of strings of Licht-Technik color changers

(All dimensions in mm!)

Sizes of markers: Begin- and Endmarker: 25 x 25mm
 Colormarker: 6,5 x 25mm vertical
 Darkcolormarker: 13 x 25mm vertical (CC/Cyclo V2.1, Sh-CC V1.1 and higher)

At the bottom end, the marker has to be placed concisely with the bottom end of the gel!

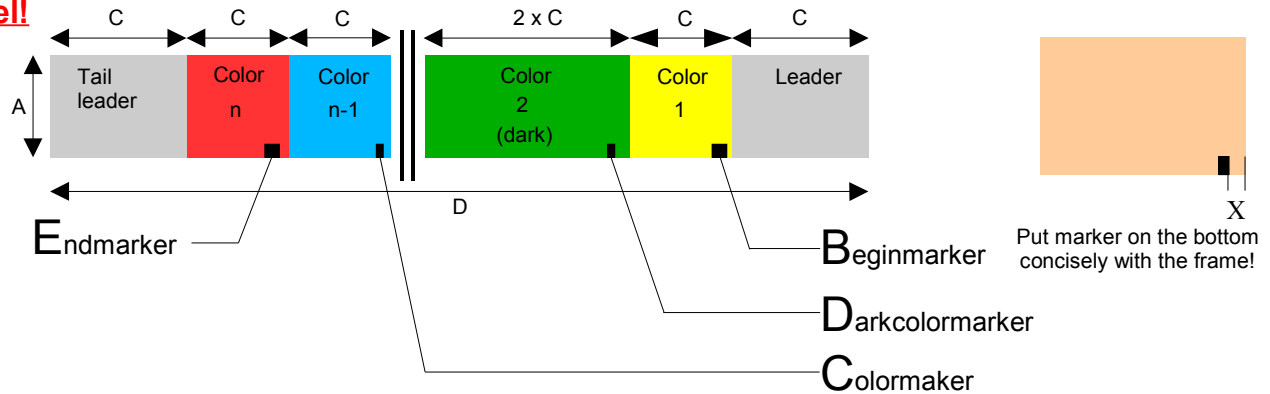

MagMax™							Position x			Revolutions for foil tensioning
Type		Color-code Cartridge	Height A	Color Length C	String Length D	Max. Colors	Color marker	Begin marker	End marker	
MM200			216	280	6160	20	50	80	15	
MM250			275	380	7980	19	70	75	45	
MM300			318	450	9000	18	70	75	45	
MM350			358	480	8640	16	65	75	45	
MM430			450	530	8480	14	60	75	20	
MM500			520	640	8960	12	65	80	30	
MM500XL			700	640	8960	12	65	80	30	
MM8-Lite			700	530	8480	14	60	75	20	

MagMax™ Mk2		MagVader		Position x						
Type		Color-code Cartridge	Height A	Color Length C	String Length D	Max. Colors	Color marker	Begin marker	End marker	
	MV175 Event		206	280	7560	25	50	50	50	5-6
MM200 Mk2		Green	225	305	6710	20	65	80	35	5-6
MM200 MK2-25		Green	225	305	8235	25	65	80	35	6-7
MM250 Mk2	MV200	Red	276	370	8140	20	65	80	35	5-6
MM300 Mk2	MV250	Black	320	440	9680	20	65	80	35	10-11
MM300 Mk2-25		Black	320	440	11880	25	65	80	35	12-14
MM350 Mk2	MV300	Yellow	370	490	9800	18	80	95	40	10-11
MM430 Mk2	MV350	Blue	450	550	9900	16	80	95	40	12-14
MM500 Mk2	MV430	Grey	530	630	10080	14	80	95	40	20-22

CC-Serie		SH-CC		Use dark color markers only with Versi on 2.1 (CC) respectively 1.1 (SH-CC) or higher						
Type			Height A	Color Length C	String Length D	Max. Colors	Position x			
							Color marker	Begin marker	End marker	
CC175			192	240	7680	30	40	30	35	
CC200	SH-CC185		225	305	9760	30	50	50	50	
CC250			276	370	9990	25	65	50	50	
CC270	SH-CC270		276	370	9990	25	65	50	50	
CC350	SH-CC325		370	465	9300	18	75	60	50	
	SH-CC460		498	580	10440	16	75	60	50	

MagMax™ Cyclo Series		Use dark color markers only with Versi on 2.1 or higher							
See Cyclo Series manual									

The revolutions for tensioning should be a reference point valid for new gels and the maximum of color frames!

Getting started

Please read the safety and operating instructions on page 5 **before** setting into operation. After that, cable the Color Changer like illustrated on page 6 or page 7.

After switching on, the LCD-display shows the *Licht-Technik* moving text in the first line. The second line shows the programmed DMX address and the corresponding DMX value (8 Bit real DMX value, 0..255). For example: *R001:128*. This is the normal operation mode.

If the moving text doesn't appear and instead of this a request for scanning the tape please refer to section *Putting in and scanning the color tape* on page 14. This request is the result of not completed previous scan.

The Color Changer is ready to be controlled by the light panel after programming the DMX addresses (menu P01/P02/P03) for color, speed and fan intensity. Refer to page 18,19,20.

In this mode it is possible to switch the LCD backlight with the UP key on or off respectively.

If you press the DOWN key the number of colorframes will be shown in the second line of the display.

With the OK key you can force the scrolling text to start new at the beginning to read the software version quickly.

The factory presettings (refer to page 36) can be resetted by pressing the keys Up and Ok during switching on the device.

Please refer to the Description of programming on page 18 (continuing) for further programming possibilities.

Please note that the tape can not be moved during programming!

Putting in and scanning the tape

The inserting of a new tape can be started from menu *P26 PUTTING IN THE COLOR STRING*. (refer to page 29), or by pressing the keys UP and OK during switching on.

The color changer itself tries to start a scanning procedure, if a previous scan wasn't successful. This can be a result of switching the device off during scanning or a incorrect position of the begin- or endmarker.

Make sure that no string is inside the device at this point!

After that, two security questions have to be confirmed. The first one is that a scan has to be performed and the second one is to make sure that no tape is inserted. If both are confirmed with the key OK the scanning is starting. Up to that point you can cancel the procedure by pressing the key DOWN (like the LCD shows).

If the scan was started, the color changer starts moving automatically to the end position. During this time the LCD display shows:

```
PLEASE WAIT!  
POT: 1234
```

The second line indicates the internal absolut value of the current position.

If the end position is reached, you will be requested to put in the tape. The display indicates the following text:

```
PUT IN COLOR STRING (READY=OK)  
POT: 4090
```

Now the string will be inserted as follows:

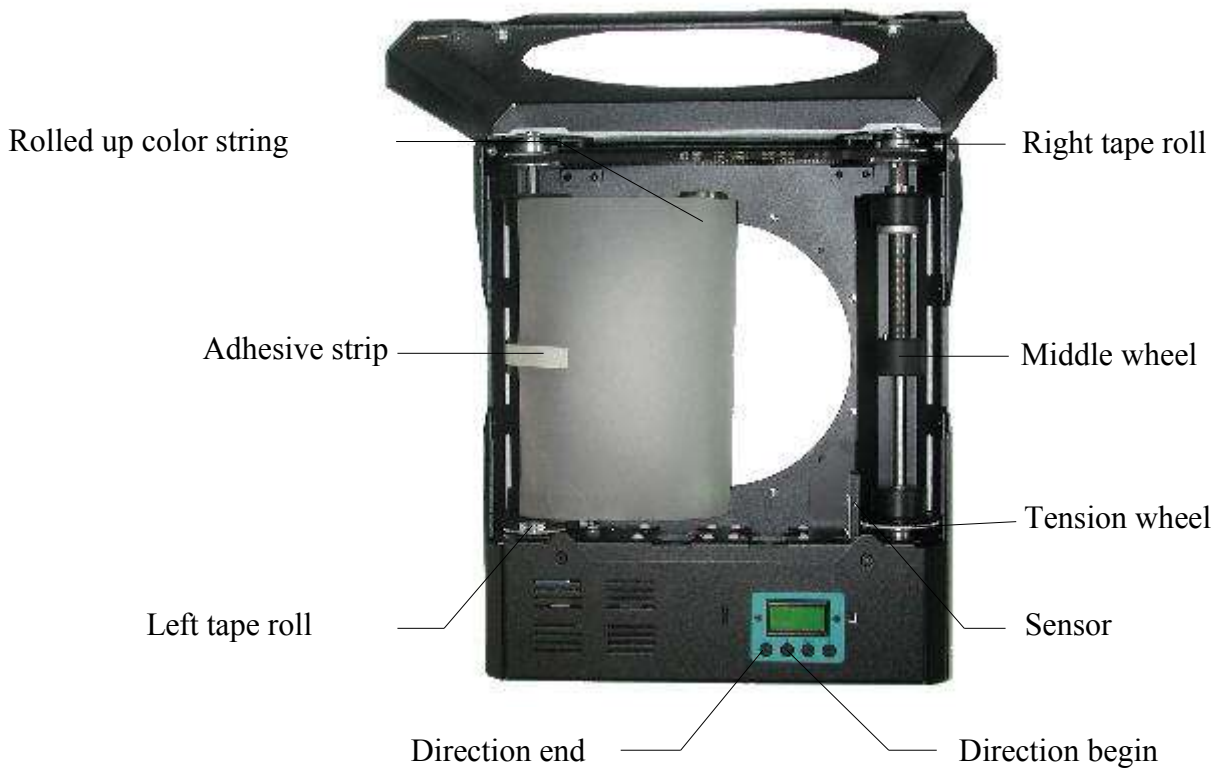

Roll up the tape so that the tail leader is the open end. Put in the color string like on the picture above and fix the tape with a high temperature adhesive strip on the middle wheel of the left roll. Now you can roll up the tape comfortably with the color changer using the key DOWN (direction begin). The UP button moves the tape in the other direction.

Now is a good opportunity to attach, change or just control the markers. (If not done already)

If the begin is reached (tape is nearly complete on the left roll), fix the tail with a further adhesive strip on the middle wheel of the right roll. Make sure that the color string is moving through the light sensor.

Wind up the tape a little bit (3 – 4 windings) by hand or the UP and DOWN keys on the right roll. Now it's time to tense the tape. To do this, you have to keep the left roll fixed and turn the tension wheel to the right side (3 – 4 times). See picture:

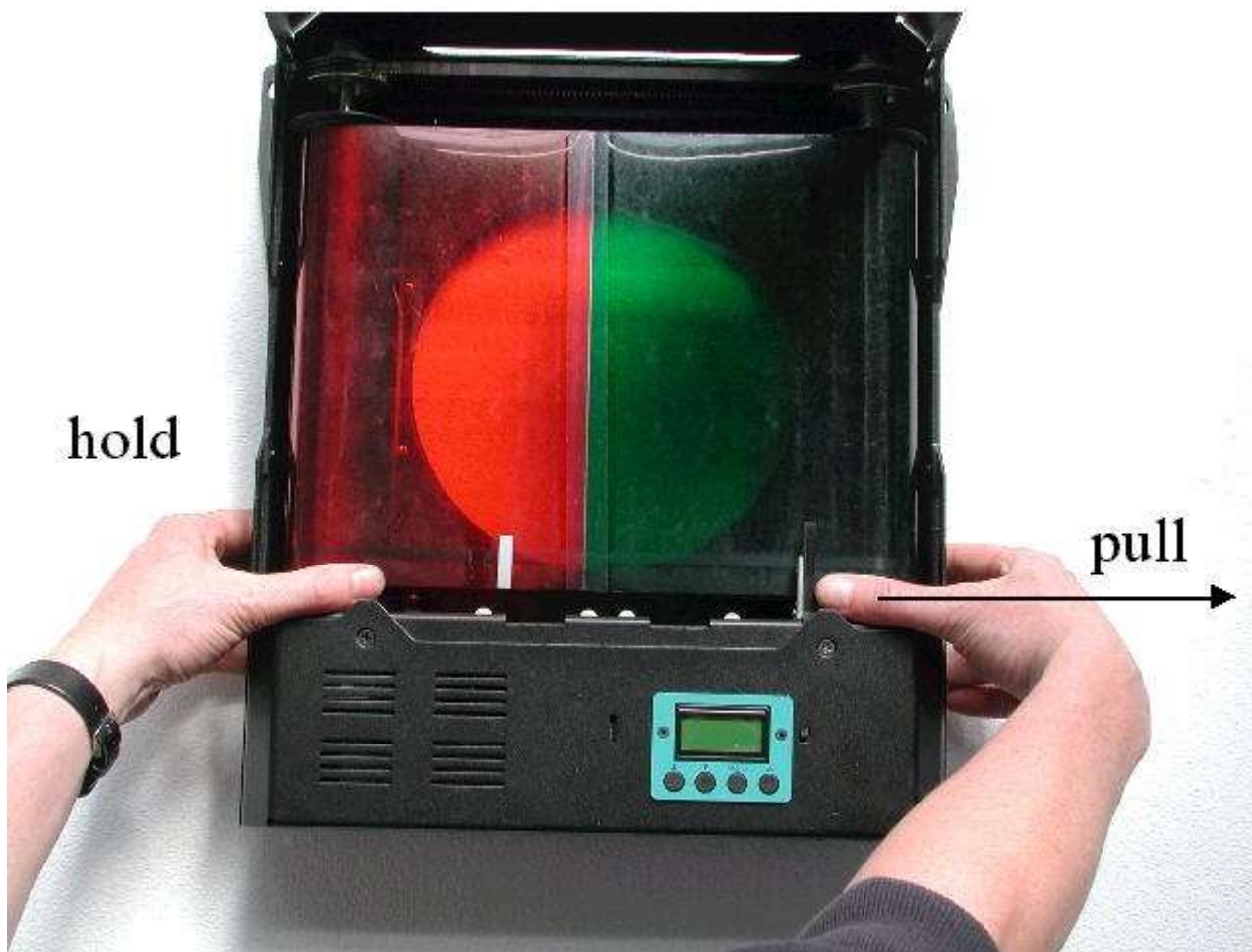

Bring the tape in middle position, so that the same quantity of the foil is on the left and right roll. Tense the foil again in the same way as before. The tension must neither be too strong nor too loose. This means, if you press down the string in the middle position, it must come up again by itself.

Important:

- Make sure that you tense foil in the middle of the color tape. On the other hand, the tension will be incorrect.
- Make sure that the markers are moving through the sensor.

When this is done, you can confirm the putting in by depressing the OK key. Make sure that the sensor is between the begin- and the endmarker. Now the color changer is starting the scan. First, the device is looking for the beginmarker. Until it is found, the second display line indicates the internal absolute value of the position. After recognising the start-marker the scanning of the color marker starts.

First line indicates the color number, the second line is blank (up to Version 2.04) or indicates the type of marker (color, darkcolor and so on). (V2.1 or higher).

If the endmarker is reached, the device moves the string to the current DMX position. After that is done the scanning procedure is finished and the color changer is in normal mode again.

You can check the number of colorframes in Menu P24 (refer to page 28) or by depressing the DOWN-key in normal operation mode. The number of colorframes must be exactly the same as the number of markers (inclusive the start- and endmarker).

Firmware version up to 2.04:

If you are using the optional darkcolor mode, you have to set the darkcolors in P10 DARK COLORS. Like described on page 24.



P01 DMX address position

At this point the DMX address of the color changer can be adapted to the address of the light mixer panel.



Range of values: Address 1..512

Operation:

-  depress Now you are at the menu level. The last adjusted menu point is displayed, e.g.:
P02: DMX-ADDRESS SPEED

-   depress ...until *P01: DMX-ADRESSE POSITION* is displayed.

-  depress The second line indicates the currently adjusted value.

-   depress Adjust the desired address.

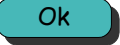
-  depress You are back on menu level.

-  depress The equipment is ready for operation.







P02 DMX address speed

At this point the DMX address for speed control of the color changer can be adapted to the address of the light mixer panel.

If the value is set to 0, the internal adjusted speed of P20 will be used. In this case it is possible to operate the color changer without a separate speed channel.

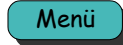
Range of values: Address 0..512

Operation:

-  depress Now you are at the menu level, the last adjusted menu point is displayed, e.g.:
`P01: DMX-CHANNEL POSITION`
-   depress until `P02: DMX ADDRESS SPEED` is displayed.
-  depress The second line indicates the currently adjusted value.
-   depress Adjust the desired DMX address.
-  depress You are back at menu level.
-  depress The equipment is ready for operation.

Caution!

If the speed channel is set to 0 the value that is adjusted at menu `P20 SPEED IF P02 VALUE IS 0` (refer to page 26) will be used as speed value. In this case it is possible to operate the color changer without a separate speed channel. This means, there is no speed control by the light mixing panel!









P03 DMX address fan

At this point the DMX address for fan intensity can be adapted to the address of the light mixer panel.

If the value is set to 0, the internal adjusted speed of P22 will be used. In this case it is possible to operate the color changer without a separate fan intensity channel.

Range of values: Address 0..512

Operation:

-  depress Now you are at the menu level, the last adjusted menu point is displayed, e.g.:
`P01: DMX-CHANNEL POSITION`
-   depress until `P03: DMX ADDRESS FAN` is displayed.
-  depress The second line indicates the currently adjusted value.
-   depress Adjust the desired DMX address.
-  depress You are back at menu level.
-  depress The equipment is ready for operation.

Caution!

If the fan intensity channel is set to 0 the value that is adjusted at menu `P22 INTERNAL FAN INTENSITY` (refer to page 27) will be used as fan intensity value. In this case it is possible to operate the color changer without a separate fan channel. This means, there is no fan control by the light mixing panel!

P04 DMX-adress Move mode

At this point the DMX address for move mode can be adapted to the address of the light mixer panel. With this value, the value of P11 (move mode color changer, page 25) can be set.

If this value is set to 0, this function is switched off.

This DMX-address is not automatically set with P08 (page 22) function. This is to avoid unintended programming of P11.







DMX-range of value for setting P11:

10 - 20:	Frame-by-Frame - Mode	(P11=1)
21 - 30:	Halbframe - Mode	(P11=2)
31 - 40:	Linear - Mode	(P11=0)
all others:	no modification of P11	

A new move mode for P11 is set, when DMX value is 5 seconds in the corresponding range of value.

Range of value: Adress 0..512

Operation:

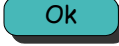
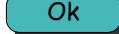
-  depress Now you are at the menu level, the last adjusted menu point is displayed, e.g.:
P01: DMX-CHANNEL POSITION
-   depress until *P04: DMX ADDRESS MOVE MODE* is displayed.
-  depress The second line indicates the currently adjusted value.
-   depress Adjust the desired DMX address.
-  depress You are back at menu level.
-  depress The equipment is ready for operation.

P08 One address mode DMX-address

At this point you can decide if the DMX addresses should be programmed individual or only the first address is set and the others follow. At Licht-Technik equipment you can go both ways: Adjust only one address (except P04) or all 3 addresses.







An exception is P04. This is to avoid unintended programming of P11.

Range of values:

P08 = 1 set only the first address (P01) the others will follow to this.

P08 = 0 you can adjust all 3 addresses individually.

Operation:

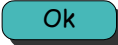
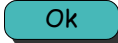
-  depress Now you are at the menu level, the last adjusted menu point is displayed, e.g.:
P01: DMX-CHANNEL POSITION
-   depress until *P08: DMX ADDRESSES 0:INDIVIDUAL 1: ONLY FIRST ADDRESS* is displayed.
-  depress The second line indicates the currently adjusted value.
-   depress Adjust the desired addressing mode.
-  depress You are back at menu level.
-  depress The equipment is ready for operation.

Note:

If a 1 is programmed at this menu, you can not set the DMX-addresses for speed and fan intensity. Only the address for position (Menu P01) can be set. The speed address is automatically one higher than the address for position. The fan intensity address is automatically two higher than the address for position.









P09 Dark color mode speed (optional extra)

Since dark color mode is an optional extra, P10 is only available in firmware versions ending with a „D“ (Refer to *Licht-Technik* moving text in normal mode). For example V1.13D.

At this menu you can program the speed for dark colors

Range of values: 0..255

Operation:

-  depress Now you are at the menu level, the last adjusted menu point is displayed, e.g.:
P01: DMX-CHANNEL POSITION
-   depress until *P09: DARK COLOR MODE SPEED* is displayed.
-  depress The second line indicates the currently adjusted value.
-   depress Adjust the desired speed.
-  depress You are back at menu level.
-  depress The equipment is ready for operation.

P10 Dark colors (optional extra)



Since dark color mode is an optional extra, P10 is only available in firmware versions ending with a „D“ (Refer to *Licht-Technik* moving text in normal mode). For example V1.1D.

If dark color mode is implemented, at this point the dark colors can be checked and, if necessary, corrected. Please note that the first and the last color cannot be set as a dark color, since these frames are marked with a begin- or an endmarker, therefore they can't be marked with a dark color marker.



Range of values: 1 to number of colors



Operation:

 depress Now you are at the menu level, the last adjusted menu point is displayed, e.g.:
`P01: DMX-CHANNEL POSITION`

  depress until `P10: DARK COLORS` is displayed.

 depress The second line indicates either:
`CO2:-----` if color 2 is a dark color.
or
`CO2:DARK` if color 2 is a dark color.

Now you can choose a color number with the keys   The color changer is moving to the selected color. By depressing  you can toggle the current color to be a dark color or not. The display indicates accordingly to your settings.

  depress You are back at menu level.

 depress The equipment is ready for operation.







P11 Move mode

At this point you can switch between linear and frame-by-frame mode. In linear mode, every position of the color tape is responsive to the light mixer panel.

In frame-by-frame mode only full colors are responsive to the panel – under the condition that each full color is marked with an aluminium marker (refer to section *Positioning of aluminium markers*, page 10).

Range of values: 0 = Linear mode
1 = Frame-by-frame mode

Operation:

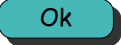
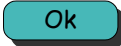





-  depress Now you are at the menu level, the last adjusted menu point is displayed, e.g.:
`P01: DMX-CHANNEL POSITION`
-   depress until `P11: MOVE-MODE: 0: LINEAR 1:FRAME BY FRAME` is displayed.
-  depress The second line indicates the currently adjusted value.
-   depress Adjust the desired move mode.
-  depress You are back at menu level.
-  depress The equipment is ready for operation.

P20 Internal speed

At this point you can define at which speed the color changer shall carry out positioning process when no DMX channel for speed control is programmed (P02, page 19 is set to 0).

Range of values: 0..255

Operation:

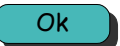
-  depress Now you are at the menu level, the last adjusted menu point is displayed, e.g.:
P01: DMX-CHANNEL POSITION
-   depress until *P20: SPEED. IF P02-VALUE 0* is displayed.
-  depress The second line indicates the currently adjusted value.
-   depress Adjust the desired value.
-  depress You are back at menu level.
-  depress The equipment is ready for operation.

Caution!









This value is only the speed value if P02, page 19 is set to 0!

P22 Internal fan intensity

At this point you can adjust internal fan intensity if no DMX channel for the fan is programmed (P03, page 20 is 0).

Range of values: 0..255

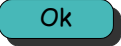
Operation:

-  depress Now you are at the menu level, the last adjusted menu point is displayed, e.g.:
P01: DMX-CHANNEL POSITION
-   depress until *P22: FAN INTENSITY IF P03-VALUE 0* is displayed.
-  depress The second line indicates the currently adjusted value.
-   depress Adjust the desired value.
-  depress You are back at menu level.
-  depress The equipment is ready for operation.

Caution!







This value is only the fan intensity value if P03, page 20 is set to 0!

P24 Number of color frames

At this point you can check the number of colors of the tape. If there is the value 0 the color string is not scanned. In this case the color changer doesn't move. Start a string scan in menu P26, page 29. At this menu nothing is programmable. It's just for information.

Range of values: 0 .. number of color frames

Operation:



-  depress Now you are at the menu level, the last adjusted menu point is displayed, e.g.:
PO1: DMX-CHANNEL POSITION
-   depress until *P24: NUMBER OF COLOR FRAMES* is displayed.
-  depress The second line indicates the number of frames.
-  depress You are back at menu level.
-  depress The equipment is ready for operation.

P26 Putting in the color string

At this point you can put in a foil and start a scan. Nothing can be programmed in this menu.

Operation:

-  depress Now you are at the menu level, the last adjusted menu point is displayed, e.g.:
PO1: DMX-CHANNEL POSITION

-   depress until *P26: PUT IN COLOR STRING ?* is displayed.

-  depress You are back at normal mode. The equipment is ready for operation.

-  depress The scanning will be started. If all security questions are confirmed the foil can be put in. For further procedure please refer to section *Putting in and scanning the tape*, page 14.



P28 Handmode

At this point it is possible to move the color frames by hand. Only full color frames can be selected (like in frame-by-frame modus). A DMX signal is not necessary.

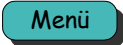

Range of values: 1 .. number of color frames

Operation:

 depress Now you are at the menu level, the last adjusted menu point is displayed, e.g.:
P01: DMX-CHANNEL POSITION

  depress until *P28: HANDMODE* is displayed.

 depress The second line indicates the current frame number. e.g.:
COLOR:01

Now you can choose a color with the keys   The color changer moves to the current color number.

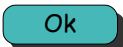
 depress You are back at menu level.









 depress The equipment is ready for operation.

P30 Show DMX

This feature helps to check the incoming DMX values. In addition at this point it is possible to set the DMX channel which value should be indicated in normal mode. The value of this address will be displayed in normal mode as long as the position-address is not changed (in P01) or the device is disconnected from power supply.

Range of values: Address 1..512

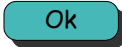
Operation:







-  depress Now you are at the menu level, the last adjusted menu point is displayed, e.g.:
P01: DMX-CHANNEL POSITION
-   depress until *P30: SHOW DMX* is displayed.
-  depress The second line indicates the currently adjusted value.
-   depress Adjust and/or check the desired DMX address.
-  depress You are back at menu level.
-  depress The equipment is ready for operation.

P32 User language

Here you can select German or English language.

Range of values: 0: German
1: English

Operation:

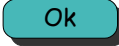
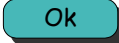





-  depress Now you are at the menu level, the last adjusted menu point is displayed, e.g.:
P01: DMX-CHANNEL POSITION
-   depress until *P32: LANGUAGE 0:GERMAN 1:ENGLISH* is displayed.
-  depress The second line indicates the currently adjusted value.
-   depress Adjust 0 for German or 1 for English.
-  depress You are back at menu level.
-  depress The equipment is ready for operation.

P35 Unit number (Netspider only)

Here you can set the unit number for netspider systems. This number is only necessary in Netspider systems. In normal DMX systems, this number has absolutely no effect.

Range of values: 0..9999

Operation:

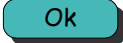





-  depress Now you are at the menu level, the last adjusted menu point is displayed, e.g.:
P01: DMX-CHANNEL POSITION
-   depress until *P35: UNIT NUMBER (NETSPIDER ONLY)* is displayed.
-  depress The second line indicates the currently adjusted value.
-   depress Adjust the desired unit number
-  depress You are back at menu level.
-  depress The equipment is ready for operation.

P51 Auto move (Demomode)

This mode is for auto moving the string. This means the string is moved automatically from one end to the other. A DMX signal is not necessary. The speed of moving is the internal speed, set in P20, page 26. The fan can be controlled with the internal mode, set in P03, page 20. Available in Firmware V2.02 and higher.

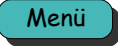
Range of values: 0 Auto move off
 1 Auto move on

Operation:

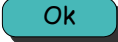
-  depress Now you are at the menu level, the last adjusted menu point is displayed, e.g.:
`P01: DMX-CHANNEL POSITION`
-   depress until `P51: AUTO MOVE (DEMOMODE)` is displayed.
-  depress The second line indicates the currently adjusted value.
-   depress Adjust the desired value.
-  depress You are back at menu level.
-  depress The equipment is ready for operation.

Technical data

Weight and dimensions:

CC175: (LxHxD)	330mm x 290mm x 70mm	2,3 kg
CC200: (LxHxD)	365mm x 390mm x 75mm	3,5 kg
CC250: (LxHxD)	400mm x 440mm x 70mm	4,0 kg
CC270: (LxHxD)	470mm x 400mm x 70mm	4,7 kg (integrated Power supply)
CC350: (LxHxD)	530mm x 540mm x 80mm	6,0 kg

Connected loads: 24 V DC, max 1,25A, 30W

PIN assignment:

Data-Power-cable:	4pin XLR connector	
	Housing: shield	
	PIN1 0V	cross-section min. 0,75 mm ²
	PIN2 Data-	cross-section min. 0,25 mm ²
	PIN3 Data+	cross-section min. 0,25 mm ²
	PIN4 +24V DC	cross-section min. 0,75 mm ²

Data line:	5pin XLR connector	
	PIN1 Shield	cross-section min. 0,25 mm ²
	PIN2 Data-	cross-section min. 0,25 mm ²
	PIN3 Data+	cross-section min. 0,25 mm ²
	PIN4 not connected	cross-section min. 0,25 mm ²
	PIN5 not connected	cross-section min. 0,25 mm ²

Please note: To avoid electrical and magnetical radio interferences, please use only screened cables. This improves also a safe operation of the devices.

The DMX wires must be twisted pair and shielded separately.

Factory presettings

Menu	Value	Description
P01	1	DMX Channel position
P02	2	DMX Channel speed
P03	3	DMX Channel fan
P08	0	Adressing mode
P09	15	Dark color mode speed
P10	1	Dark colors
P11	1	Move mode
P20	128	Internal speed
P22	128	Internal fan speed
P24	none	number of color frames
P26	none	Putting in and scanning a tape
P28	1	Handmode
P30	0	Show DMX
P32	1	User language
P35	0	Unit number (Netspider only)
P51	0	Auto move (Demo mode)

Note:

The factory presettings can be resetted by pressing the keys Up and Ok during switching on the device.

Error messages / Failures

No display after Power up:

- Check cable connections to the device
- The Equipment houses a slow-blow fuse for currents of 2A protecting the Color changer from wrong polarities in the supply line. When fuse is blown, it is absolutely necessary to check cable and polarity (PIN1 = 0V, PIN4 = 24V).

Error 30: Motor/Potentiometer blocked

- Check, if there is any foreign object inside the device
- Check, if the drive can move easily
- Check cable connections to motor and potentiometer connections are reversed, if motor or potentiometer was changed

Error 28: EEPROM

- Please contact *Licht-Technik*

Error 21: DMX signal reversed

- Check input line if Pin 2 and Pin 3 are interchanged.
- Check DMX supply cable to the Power supply unit (splitbox) if Pin 2 and Pin3 are interchanged

Error 20: DMX signal missing

- Check if one or more pins of the input cable to the Shutter are broken.
- Check DMX supply cable to the Power supply unit (splitbox) if used, DMX OK LED must light.
- The light mixer panel is not operative.

Error 41: Too many frames

- Make sure that there are not more than the given number of markers used. Refer to page 9.

Error 43: Color string too long

- Make sure that the tape is not longer than dimension D (total length of tape). Refer to page 8.

Error during putting in/scanning the foil

- Check if the markers are moving through the light sensor. Make sure that the markers are not inclined. They have to be exactly vertical.
- Wrong markers and strong front light can lead to a malfunctioning of the sensor
- Settings for dark and normal colors can be corrected at *P 10 DARK COLORS* (page 24)

If the error cannot be recovered, contact please the company Licht-Technik

Warranty

The warranty for this color changer is 2 years. It comprises any repair of failures – free of charge – which can be proved to result from defects of fabrication.

Warranty expires when:

- the device was modified or attempted to be repaired
- damages were caused by the intervention of foreign persons
- damages are due to noncompliance with the operating instructions
- the device was connected to an incorrect voltage or incorrect type of current
- the device was incorrectly operated or when damages were caused by negligent handling or misuse

Further information

This document and the information contained therein are subject to copyright and neither the whole nor any part of it may, and this is also valid for the described product, be reproduced, copied or recorded in any form without the prior written authorization of *Licht-Technik Vertriebs GmbH*.

The products of *Licht-Technik GmbH* are subject to constant development. Therefore *Licht-Technik* reserves the right to modify components, motors and also technical specifications any time and without prior notice.

All maintenance and servicing works related to the product must be carried out by the company *Licht-Technik*. *Licht-Technik* shall not assume any liability for losses or damages of any kind being the results of inexpert servicing.

Declaration of conformity

Manufacturer: Licht-Technik Vertriebs GmbH
Address: Osterwaldstraße 9-10
80805 München

declares that the product:

Name of product: Color Changer
Type of product: CC200, CC270, CC350

corresponds to the following specifications under strict observance of the installation instructions and technical specifications:

**Standard 2004/108/EG of the European Parliament and the council from
15. December 2004
for law provision adaptation of the member states concerning the electrical
compatibility and for
abrogation of standard 89/336/EWG.**

The device passed the test. A testreport is available at company Licht-Technik Vertriebs GmbH.

Munich, 19.9.2005



Uwe Hagenbach / Bernhard Grill
Managing directors