

Motoryoke

**MB Studio 2000 DMX
MB tube DMX**

Software version 4.51

Functional description MB Studio 2000 DMX
MB Tube

Fabrication and marketing
Licht-Technik Vertriebs GmbH
Hagenbach & Grill
Osterwaldstr. 9-10 80805 München
Tel. 089-360528-0 Fax 089-360528-30
Last updated on: 05/12/11 Rev.: 2.24

Caution! Operate the device only after having read and **understood** operating instructions!

Table of content

The Licht-Technik Motoryoke.....	4
Identification.....	5
Safety- and operating instructions.....	6
The DMX-standard in lighting.....	9
Cabling.....	10
Getting started.....	12
PAN – axis moving range.....	13
User interface.....	17
Display lighting ON/OFF.....	18
DMX channels motoryoke.....	19
P01 DMX-Address motoryoke.....	20
P02 Focus unit ON/OFF.....	21
P03 Motorised barndoor ON/OFF.....	22
P04 DMX-address power switching.....	23
P05 PAN-axis middle position.....	24
P06 TILT-axis 0-position.....	25
P07 Barndoor rotation middle position.....	26
P11 PAN-axis moving range.....	27
P12 TILT-down (negative) moving range.....	28
P13 TILT-up (positive) moving range.....	29
P14 Focus unit 0%-value adjustment.....	30
P15 Focus unit 100%-value adjustment.....	31
P16 Barndoor 1 closed position.....	32
P18 Barndoor 2 closed position.....	33
P20 Barndoor 3 closed position.....	34
P22 Barndoor 4 closed position.....	35
P23 Barndoor 1..4 moving range.....	36
P24 All barndoors closed position adjustment	37
P25 Barndoor rotation moving range.....	38
P27 Speed PAN/TILT setup.....	39
P28 Barndoor automove function ON/OFF.....	40
P30 Displaying the DMX-value.....	41
P32 Selecting the user language.....	42
P35 Unit number Netspider.....	43
P36 Interchanging PAN moving direction.....	44
P37 Interchanging TILT moving direction.....	45
P38 Interchanging Focus moving direction.....	46
P39 Interchanging barndoor rotation moving direction.....	47
Technical data.....	48
Readjustment of motoryoke axis.....	50
Factory presettings.....	51
Maintenance.....	52
Error messages.....	54
Malfunctions.....	55
Warranty.....	56
Further information.....	56
Declaration of conformity.....	57

The Licht-Technik Motoryoke

The motorized yoke of Licht-Technik is a **versatile**, **precise** and **powerful** device for headlight positioning.

Since 1991 the company Licht-Technik designs motoryokes for film, TV and theatre houses. We only use the best components of the world-wide leading companies. The **aluminium** housings are characterised by high stability, high quality and low dead weight. The devices are manufactured on own **CNC** controlled machines and can guarantee a continuously **high quality standard**. Noise is optimised sequentially and provides thereby for extremely quiet positioning of the headlights. We manufacture the Motoryokes in co-operation with our customers for the desired sizes.

The control is made by the **DMX-512 USITT**-interface. The rough and fine positioning and the speed for each main-axis (PAN/TILT) can be controlled. As an option a focus unit and/or a motorized barndoor can be controlled by DMX.

The Motoryokes can be offered with the following **options**:

Focus unit:

With the focus unit the headlight-focus can be driven by DMX. The positioning takes place in 256 steps (1 DMX channel). The speed is fixed. Therefore no DMX-channel for speed has to be set.

Motorised barndoors:

A motorized 4-wing-barndoor can be controlled by the yoke. The positioning takes place in 256 steps (1 DMX-channel for every barndoor and 1 channel for rotation). The rotation can turn 182 degrees. The barndoors opens 125 Grad at maximum. The motorized barndoor has an intelligent controlling (automove function) so that no crash will occur when 2 or more wings will be closed or opened.

Power switching for dual filament bulb:

For dual filament bulbs we can offer a switching unit. It is possible to switch between the different filaments. It is working contactless so that the studio equipment will not be disturbed. Up to 5 kW can be switched.

The built in **32-Bit Processor** provides a high throughput of the computer, quick positioning and uncomplicated handling. Even when triggering several motoryokes the precise control system provides a high synchrony of the movement.

Because of the absolute value device, the motoryoke does not perform any **initialisation runs** after power up.

The lighted **LCD display** (the light can be switched off) leads the user in plain text instructions through the various programming steps. The instructions are available either in english or german language.

The motoryoke has a mechanical and electronical **torque delimitation** on the PAN and TILT axle. The mechanical torque limitation is realised with a friction **clutch** and prevents a personal injury of people working on the yoke. Furthermore the drives and gearboxes will not be damaged when moving the yoke in case of power off.

The **electronical torque delimitation** switches off the motors in case of blocking (e.g. blocking because of moving onto a wall or decoration). The display shows an appropriate error message.

The **controlling** of the two main axes (PAN and TILT) is done with 2 DMX-channels per axle. With only one channel (8-Bit) a resolution of 256 steps could be realised. With two channels (16-Bit) a resolution of **65536 steps** is possible. The first channels of each axle represents the rough position information (at 360° range of rotation about 1.4 degrees per step). The second channel represents the fine position information. The speed of the motoryoke is determined with one channel (PAN and TILT together) or with two channels (PAN and TILT separated).

Identification

The motoryokes are **identified** by a number on the identification plate as follows:

MB – XX / Y ZZZ

MB = Motoryoke. On every motoryoke identification plate.

XX = ST: Type: Studio yoke
R: Type: tube yoke
SH: Type: Show yoke

Y = A: Small size
B: Medium size
C: Big size

ZZZ = 3 digit number e.g. 008, 013 etc.
Determines the geometry and size (e.g. length of the arms)
Numbering not sorted by anything.

Safety- and operating instructions

The motoryokes are tested by the german trade association (*Berufsgenossenschaft*). The devices conform with BGV C 1 and **correspond** to the newest safety regulations.

Never exceed the maximal possible **load of the mounting point**. (Rigg etc.)

Make sure that the **maximum load** of the fastening spigot will not be exceeded.

Never exceed the **maximum load** of the motoryoke. It is written on the identification plate.

The Motoryoke must only be operated in the **operating position** provided for this purpose. Operating position is vertically hanging down, fastening spigot on the top.

Make sure that all fixtures of the yoke are **tightened**. Observe the torque of the screws or nuts.

Fast the headlight and all accessories like color changer, dimmer shutter and barndoor with **safety belts**. See picture:

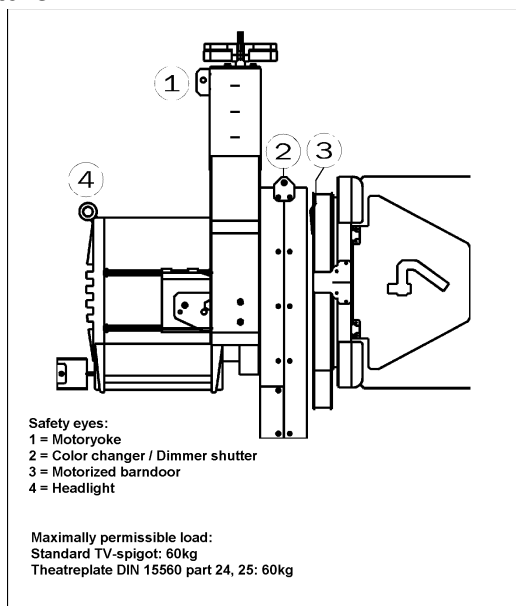

Make sure that the safety belts have the right diameter. For weights up to 60 kg a belt of 10mm diameter is necessary for the one way method and a belt of 6mm is necessary for the two way method.

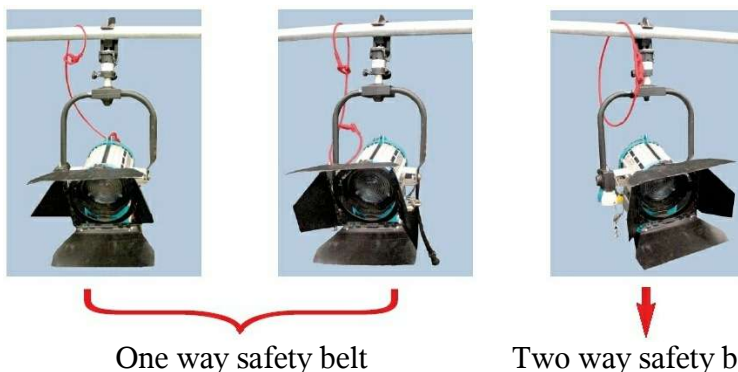

The user is **responsible** for the correct use of safety parts!

Make sure that all parts which are mounted on the headlight are right **tightened**.

Lever forces must not have an effect on the Motoryoke. This means that the installed motoryoke must not be **shifted** or **bended**! It is also forbidden when fastening spigot is opened.

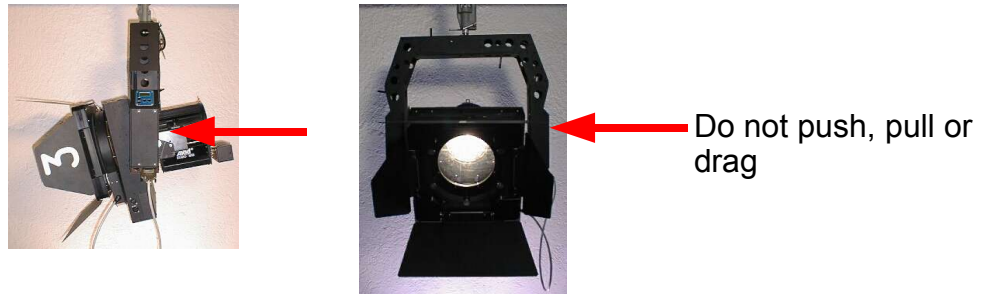

That applies also to the **transport**. It is absolutely forbidden to hang up the yoke on its spigot when transported!

If you want to use a transport **carriage**, it must be certified by Licht-Technik!

The fastening spigot must be **checked visual** once a year. The spigot must be in right angle to the housing. This must be checked in **front** and **side** view. A **protractor** can be a help.

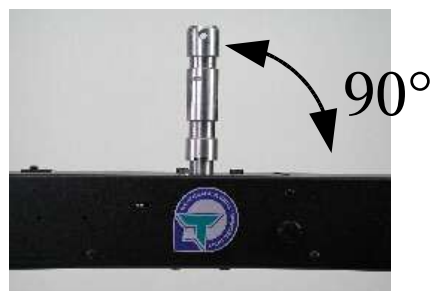

Furthermore, the **spigot** itself and the **surface** of the yoke must not be deformed. Make sure that the spigot is not loose or unformal.

If the spigot is visibly **damaged** or deformed the motoryoke must not be used anymore. The device has to be sent to Licht-Technik.

A safety device that was **once loaded** or is visibly damaged **must not** be used anymore!

When working on the motoryoke, it must be **switched off** or the power line must be interrupted. Make sure that the Motoryoke cannot be moved by the control panel.

The operator must make sure that **no person** is in the swivelling range of the motoryoke. Inform your coworker and colleagues that the motoryoke is behaving like a work robot. When the position is changed at the control panel the device is trying to move on this position. There is the danger of being bruised and get frightened.

Admissible ambient **temperature**: 0..45 degree Celsius.

The motoryoke must not be **lit directly** by the lamp. Limit the range of rotation (TILT axle) so that the headlight **does not shine** on the motoryoke.

Check the whole swivelling range of the headlight. The manufacturers of the lamps specify **minimum permissible distances** to inflammable materials. Make sure that these distances are attended in every position of the lamp.

The manufacturers of the lamps specify maximum **inclination**. HMI headlights are not allowed to operate with the ignition electronic on the top.

The motoryoke must be kept **dry**. In case of water condensation a waiting period of up to 2 hours is necessary until acclimatisation is reached.

If **knobs** for manual moving are mounted, they can only be used if the motoryoke is in power off condition. If the device is switched on and the knobs are rotated manually the motors and/or gearboxes can be damaged.

Power supply of Licht-Technik Motoryokes via the DataPower input must only be realised via power supplies **authorised** by us (safe electrical separation from the mains).

The motoryoke is **balanced** in the factory with all (optional) additional devices (color changer and/or dimmer shutter and/or barndoor and/or Focus). The motoryoke must only be operated with this additional devices to keep the balance, otherwise the motor and/or gearbox can be damaged.

When it has to be assumed that a **safe operation** is no longer possible, the equipment must be switched off immediately and be **secured against unintended** operation.

This is the case when

- the equipment shows visible damages
- the equipment is no longer functional
- parts of the equipment are loose or slackened
- connecting lines show visible damages

Attention:

Before starting the equipment the user must check the usefulness of the device for its intended use.

We reject every **liability**:

- Damages and indirect damages or every kind of costs, which result from the use of Licht-Technik products.
- Any damages which result from negligence, improper use and setup, wrong setting into operation and use, ignoring of valid safety regulations, unsuitable use, bad maintenance of Licht-Technik products.

The DMX-standard in lighting

Because of many problems with **analogue** data-signals from the control panels to the dimmers the DMX-standard was developed in 1990. DMX only needs **two** wires to control up to 512 dimmers digitally. On the other hand, the old analogue method needs one wire for every dimmer. Many kilometers of cable have been saved.

The DMX-signal is based on the industrial **RS485** interface. It is designed for maximum lengths up to 1200m. Normally this length is under condition in theatre or studio **not possible** (strong electrical fields because of the HMI lamps). As a result of internal tests we recommend a maximum length of **200m** (only DMX line, 5pin). On every DMX transmitter a maximum of 32 DMX receiver can be connected. All devices must be connected in a **row** (cabling from A to B, from B to C, from C to D etc.). The last device in such a row must be terminated with a resistor (470 Ohm). If more than 32 devices should be connected a booster or **splitbox** must be inserted.

A **splitbox** is a device with one DMX input and several DMX outputs. The signal is refreshed. Thus it is possible to use different DMX lines.

The reliability of data transmission was increased because of using DMX. One of the greatest advantages is universally usefulness. Now devices from different manufacturers can be controlled by every control panel.

Cabling

Make sure that the motoryoke is **switched off** before cabling!

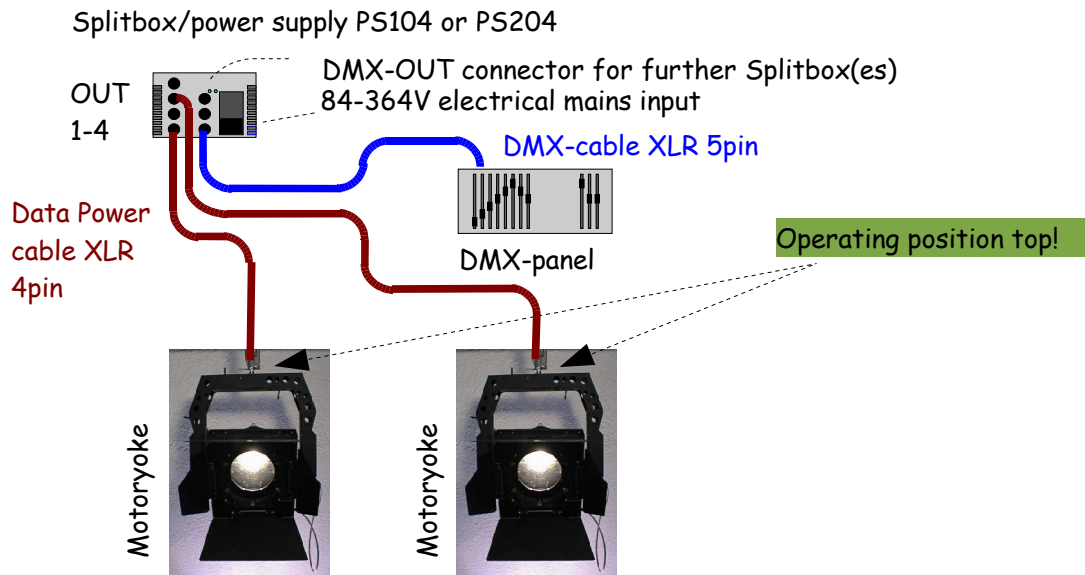

For pinout of cables refer to *technical data, page 48*.

Make sure that the connected power does **not exceed** the maximum power output of the power supply. Keep shutters and color changers in mind which are possibly connected. The maximum required power per device is always given on the identification plate. All devices together, which are connected to the power supply, must not exceed the power output of the power supply.

If only motoryokes should be connected, use this table:

Power supply	Power output	Maximum number of yokes
PS104	240W	2
PS204	480W	4

Caution!!

Make a **loop**, which is large enough, in the data power cable and the lamp cable. Make sure that there is enough space in cabling over the entire moving range of the yoke. The cables must neither be **stretched** nor **bended**!

The cables are fixed with cable fixers. The clips are mounted on the back side of the yoke. It is possible to connect a Licht-Technik color changer and/or a dimmer-shutter. The last device of a DMX-chain should be terminated with a terminating resistor (470 Ohm). The maximum length of a DMX-chain must not exceed 80m.

Furthermore a **motorised barndoor** (25pin Sub-D) and/or a **focusunit** (5pin XLR) and/or a **power switching** for dual filament bulb (3pin XLR) can be controlled by the yoke:

The **connection possibilities** of the studio motoryoke:

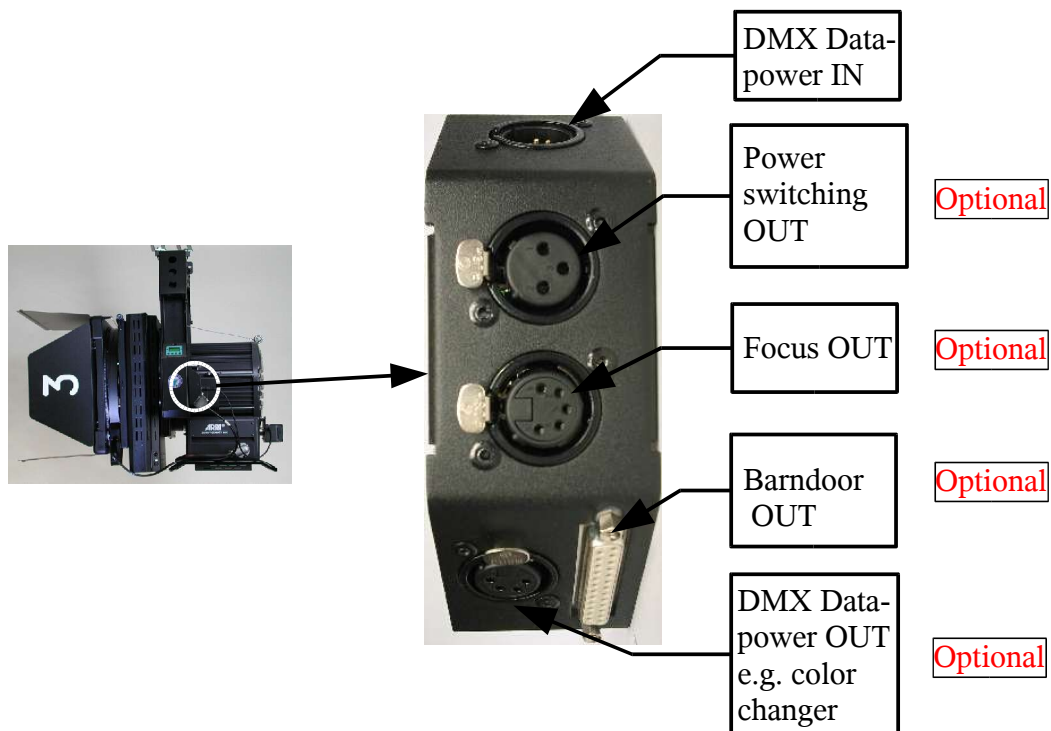

The **connection possibilities** of the tube version:

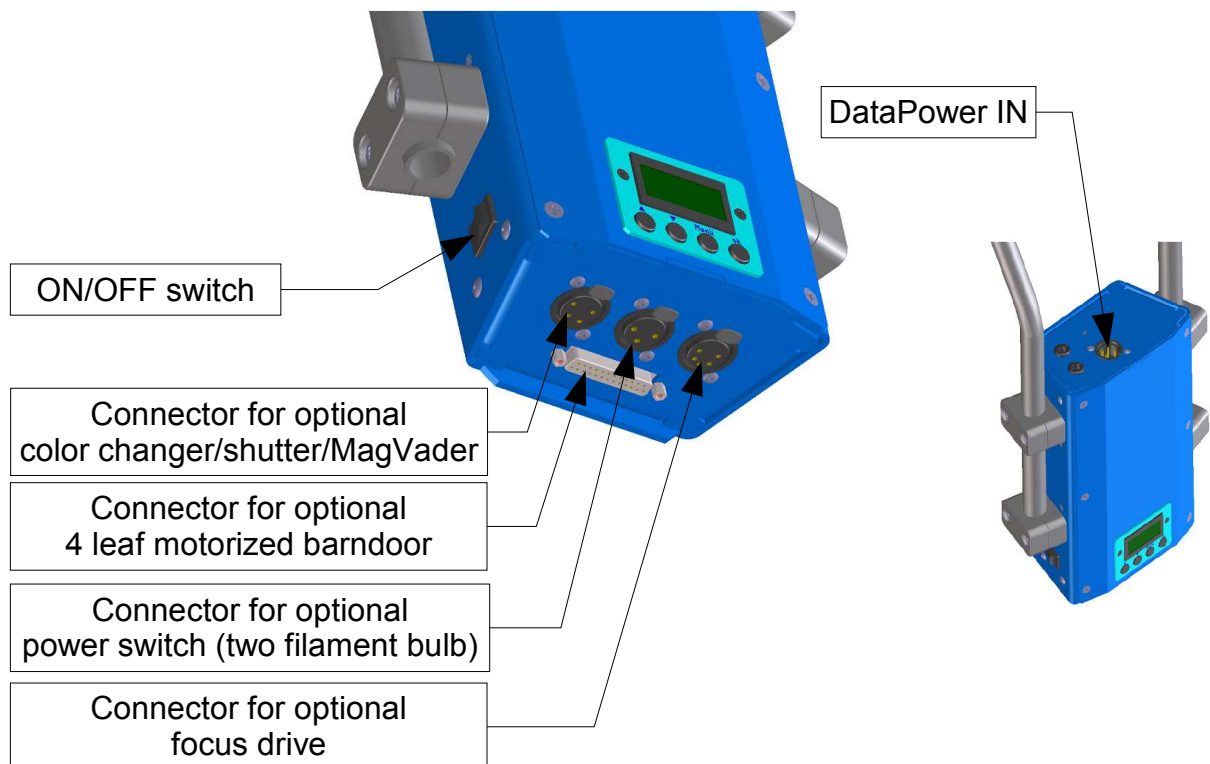

Getting started

The motoryoke is **balanced** in factory for the desired lamp with optional accessories (shutter, color changer, barndoor, Focus, power switching). The yoke must only be operated with this lamp and accessories. The accessories must not be removed, because this changes the balance. The motors and gearboxes can be damaged.

Setup the motoryoke on the desired place **according** to the *operating and safety instructions, page 6*.

Cable the motoryoke like illustrated in *cabling, page 10*.

Switch on the motoryoke. After testing its internal program memory and the control it shows the overall operating hours. Now the motoryoke is moving to the programmed position. The second display line shows the DMX-address and value of the PAN-axle.

Caution!

Make sure that the motoryoke is not moved by the **control panel** before programming. Otherwise the motoryoke will move during programming if the position is changed at the panel!

Program the **moving range** of the **PAN**-axle. Refer to *PAN-axle moving range, page 13*.

Normally not necessary, but possible is the programming of the **TILT moving range**. Refer to *TILT-axle moving range, page 15*.

Further programming possibilities like DMX addressing are specified on the following pages.

Tip:

When the motoryoke is in **programming mode**, all moving orders are ignored. Make sure that the device is in operating mode after programming, otherwise it will not move! Press two times the OK key for leaving the programming mode!

PAN – axis moving range

Basically:

The PAN-axe is the axle which moves the lamp **horizontally**.

The **moving range** of the main axes can be adapted individually. For the PAN-axe are two parameters required. The **middle position** and an **angle** in which the motoryoke should move. Is an angle of 90 degrees programmed the motoryoke moves from its middle position 90° to the left and 90° to the right. The whole moving range is 180°.

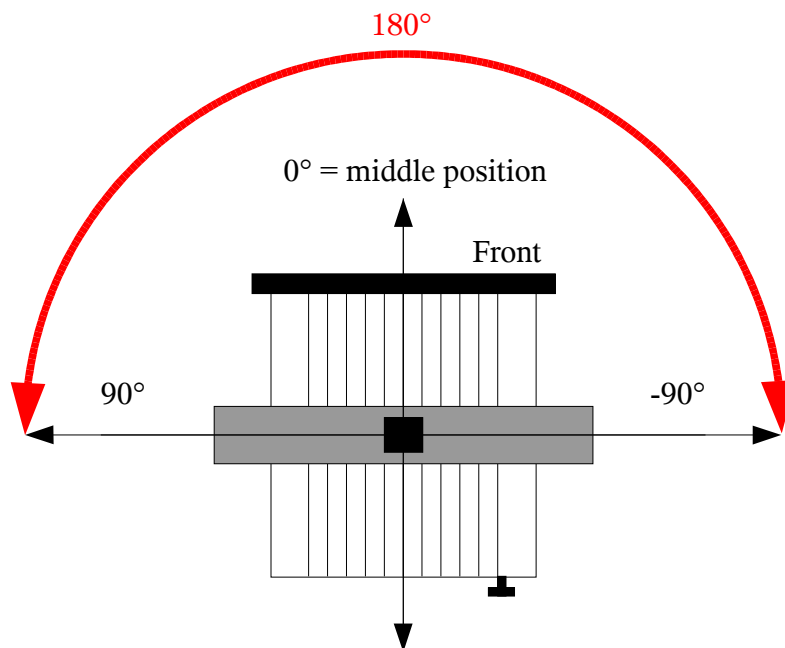

If an angle of 45° is programmed, the yoke will move 45° to the left and right. The moving range is 90°.

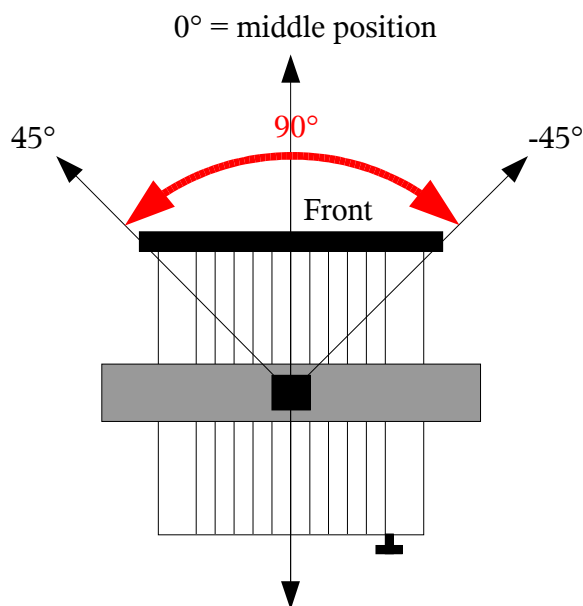

This setup is useful when the motoryoke is hanging in a **corner** for example.

Setting the PAN middle position:

The middle position normally is the position in which the lamp is **used most**. For programming, set the DMX-value of the PAN-axle and the PAN-axle-speed to **50%**. These are channels 1 and 5 at factory presets.

Let yoke move onto this position. After that the middle position can be set. Exert the **tripping lever** with a small screwdriver. Turn the yoke **carefully** on its arms onto the desired middle position. Keep the tripping lever pressed.

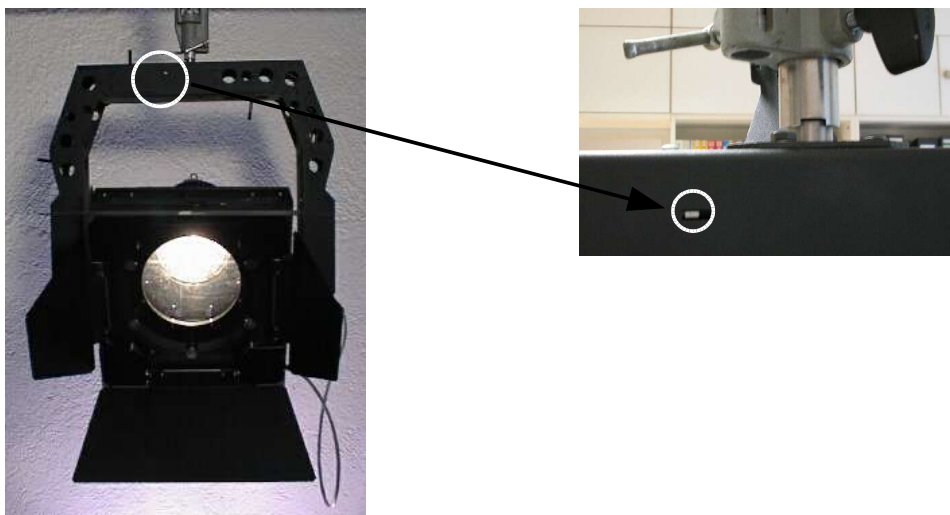

For understanding: Because of exerting the tripping lever, the motoryoke remains **internally** on its middle position. The absolute value device does not join in turning anymore. You turn the yoke around this internal middle position.

Testing of the new setting: Change the DMX-value of the PAN-axle for a few seconds, after that set it back to 50%. The motoryoke moves to its new middle position. The rough position is now programmed. In menu P05, PAN-axle middle position, page 24 the fine adjustment can be done.

The **moving angle** can be set in menu P11, PAN-axle moving range, page 27. It can be in a range within 1 and 185°.

Caution !!

Check the **entire moving** range of the lamp:

The lamp-manufacturer specify **minimum distances** to inflammable materials. Never fall below the minimum distance in no position of the lamp!

Make sure that no cable will be **broken, bended, stretched** or **damaged** anyhow by reason of turning the motoryoke!

TILT – axis moving range

Basically:

The TILT-axe is the axle which moves the lamp **vertically**.

Normally the factory presettings are **suitable** and nothing must be set. The lamp can be moved from vertically down to a few degrees on the top.

The 0-degree position represents the **horizontal even** position of the lamp. From this position a **positive** moving range and a **negative** moving range is defined. The positive range is much smaller than the negative range. This is the reason why it can not be determined where the 50% DMX position is.

TILT moving range is in opposite to the PAN moving range asymmetric. It is set in two menus. (P12, page 28 and P13 page 29).

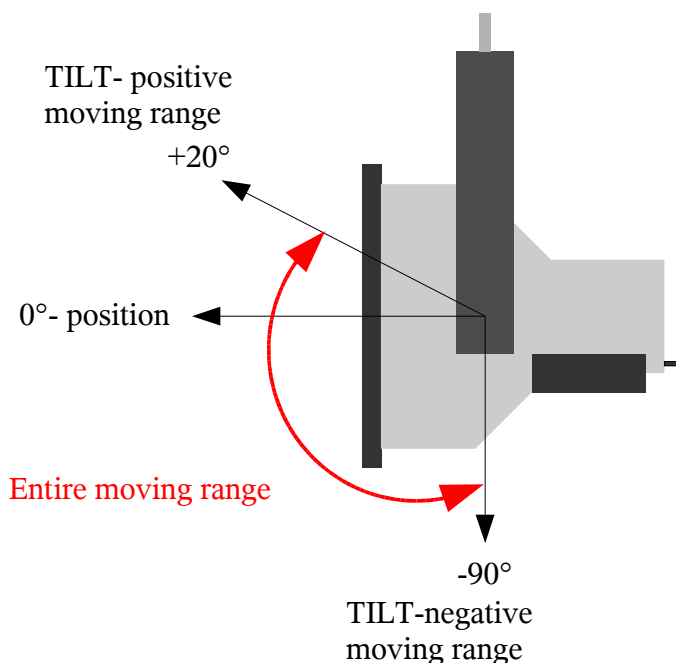

If a correction must be made do proceed with the following steps:

Use menu *P06, TILT-axe 0-position, page 25*, to move the yoke onto 0-position. When the value is changed one time (up or down), the yoke starts moving on this position.

Wait until the motoryoke **does not move** anymore.

Now it is possible to set a **new 0-position** by exerting the tripping lever. Another possibility is to use *P06, TILT-axe 0-position, page 25*.

Using the tripping lever:

Push in the lever on the front side of the yoke with a screwdriver. Keep it depressed and move the lamp onto the desired 0-position. Change the value of P06 one time. The motoryoke will move exactly onto the new 0-position.

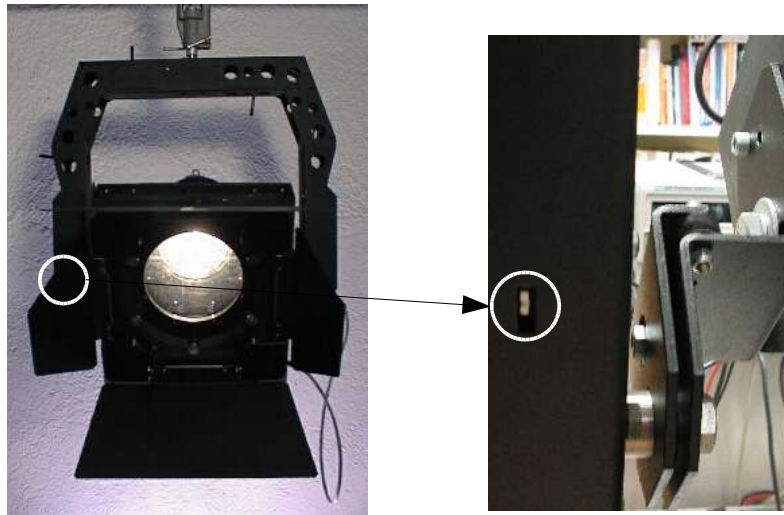

Now the **angles** for the moving range in P12 and P13 can be set. New reference point is the 0-position from before.

Do not forget to press **two** times the **OK** key to get back to working level after programming.

Check the complete new moving range with the **DMX-signal**.

Caution !!

Check the entire **moving range** of the lamp:

The lamp-manufacturer specify **minimum distances** to inflammable materials. Never fall below the minimum distance in no position of the lamp!

Check that the **motoryoke** will not be illuminated when lamp is on top position.

Make sure that no cable will be **broken, bended, stretched** or **damaged** anyhow by reason of turning the motoryoke!

Headlights generally must **not** be operated with the ignition electronic on the top. Observe the specifications of the lamp manufacturer!

User interface

Moving text with type of device, software-version and telephone number



In normal operating mode the **LCD-display** indicates different information. The first line shows the Licht-Technik moving text with details on type of device, software version and telephone number. The second line indicates the first DMX-address and its incoming value (8-Bit, 0..255). For the motoryoke, this address is the PAN-address.

With the four **keys** the device can be programmed. Instruction for this, is on the following pages.

As an optional extra we can offer the **external filament switch**. This means, the load will can be switched manually. If a switch is in "ON" position the corresponding filament will **light independently** from the control panel. If the switch is in "OFF" position the control can be done by the control panel.

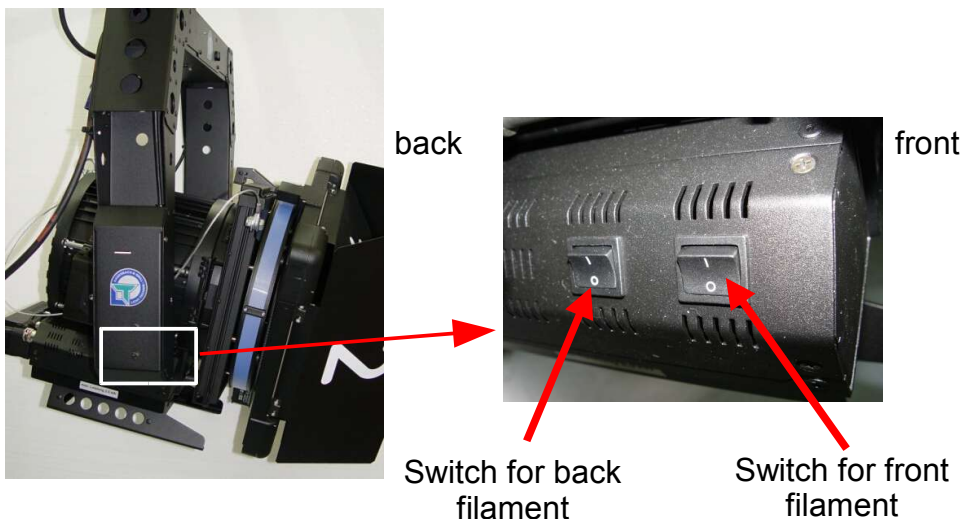

Display lighting ON/OFF

In normal operation the LCD backlight is switched off to avoid a disturbing light. Only if an error occurs or during programming the light will be switched on automatically. The user can also switch it on manually to see what is indicated.

Condition: Motoryoke is on working level

Operation:



depress. Display lighting **ON**



depress again. Display lighting **OFF**

DMX channels motoryoke

The following chapters require the **DMX-channel assignment** of the motoryoke. Please note the difference which is programmed in *P27, PAN/TILT DMX speed channel setup, page 39*. This menu determines if the speed is given by **one** or by **two** channels. Therefore, the motoryoke requires between 5 (without optional components) and 12 DMX-channels.

Channel	Motoryoke (P27=0)	Motoryoke (P27=1)
1	Rotation PAN rough	Rotation PAN rough
2	Rotation PAN fine	Rotation PAN fine
3	Rotation TILT rough	Rotation TILT rough
4	Rotation TILT fine	Rotation TILT fine
5	PAN/TILT speed	PAN speed
6	Focus (optional)	TILT speed
7	Motorized barndoor, leaf 1 (optional)	Focus (optional)
8	Motorized barndoor, leaf 2 (optional)	Motorized barndoor, leaf 1 (optional)
9	Motorized barndoor, leaf 3 (optional)	Motorized barndoor, leaf 2 (optional)
10	Motorized barndoor, leaf 4 (optional)	Motorized barndoor, leaf 3 (optional)
11	Motorized barndoor, rotation (optional)	Motorized barndoor, leaf 4 (optional)
12	-----	Motorized barndoor, rotation (optional)

The **first** address (PAN rough) is set in menu *P01, DMX-address motoryoke, page 20*. All other addresses **follow** after this first address according to this table.

Examples:

1. Motoryoke with **all** optional components and P27 set to 1 (like right column in table). The next free DMX-channel would be number **13**.
2. Motoryoke **without** any additional components and P27 set to 0. Next free channel would be channel **6**.
3. Motoryoke with motorized **barndoor**, but without Focus unit and P27 set to 0. The next free channel is number **12**. Address **6** is unused and could be used by other devices which require only one channel.

Please note!

The DMX-address of the **power switching** unit is individual programmable in menu P04, DMX address power switch, page 23!







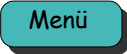

Color changer, dimmer shutter and the combined device „MagVader“ are controlled by their **own** electronic. These devices are completely independent regarding the electrical control!

P01 DMX-Address motoryoke

At this point the **first** DMX-address of the motoryoke can be adapted to the desired DMX-address of the light mixing panel. This address represents the PAN-DMX-address. All other addresses follow this address. Refer to *DMX-channels motoryoke, page 19*.

Range of values: Address 1..512

Operation:







-  depress You are now on menu level. The last adjusted menu point is displayed, e.g.:
`MENU P02: FOCUS MODULE ON/OFF`
-   depress ... until `MENU P01` is displayed.
-  depress The second line displays the currently adjusted value.
-   depress Adjust the desired DMX address.
-  depress You are back on menu level.
-  depress The equipment is ready for operation.

P02 Focus unit ON/OFF

At this point an optional **Focus** module can be switched ON or OFF. If a Licht-Technik focus unit is mounted set this menu to 1, on the other hand if no focus module is mounted set this menu point to 0. The speed of the focus is fixed, so no speed channel has to be set.

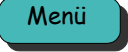
Range of values: 0: No focus module installed
1: Focus module installed

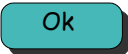
Operation:







-  depress You are now on menu level. The last adjusted menu point is displayed, e.g.:
`MENU P01: DMX ADDRESS MOTORYOKE`
-   depress ... until `MENÜ P02` is displayed.
-  depress The second line displays the currently adjusted value.
-   depress Adjust the desired value
-  depress You are back on menu level.
-  depress The equipment is ready for operation.

P03 Motorised barndoor ON/OFF

At this point an optional **barndoor** can be switched ON or OFF. If a Licht-Technik barndoor is mounted set this menu to 1, on the other hand if no barndoor is mounted set this menu point to 0. The speed of the barndoors and barndoor-rotation is fixed, so no speed channel has to be set.

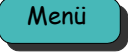
Range of values: 0: No barndoor installed
1: barndoor installed

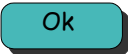
Operation:







-  depress You are now on menu level. The last adjusted menu point is displayed, e.g.:
`MENU P01: DMX ADDRESS MOTORYOKE`
-   depress ... until `MENU P03` is displayed.
-  depress The second line displays the currently adjusted value.
-   depress Adjust the desired value
-  depress You are back on menu level.
-  depress The equipment is ready for operation.

P04 DMX-address power switching

At this point the DMX-address of the optional **power switching** unit can be adapted to the desired DMX-address of the light mixing panel.

Range of values: 0: no power switching unit installed
1..512 DMX-address 1..512 of the power switching unit

Operation:

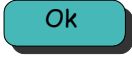
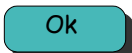
-  depress You are now on menu level. The last adjusted menu point is displayed, e.g.:
MENU P01: DMX ADDRESS MOTORYOKE
-   depress ... until *MENU P04* is displayed.
-  depress The second line displays the currently adjusted value.
-   depress Adjust the desired DMX address.
-  depress You are back on menu level.
-  depress The equipment is ready for operation.

DMX-Range of value	Powered firmament(s)
0 – 63	none
64 – 127	1
128 – 191	2
192 – 255	1 and 2





P05 PAN-axis middle position

With this function the **PAN-axis fine adjustment** of the middle position can be made. Please read first chapter *PAN-axis moving range*, page 13. This function can only be used for **fine** adjustment.

Range of values: 2000..2100 unit (value of the absolute value device)

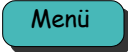
Recommended value: 2048

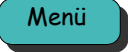
Operation:

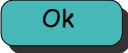
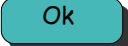
-  depress You are now on menu level. The last adjusted menu point is displayed, e.g.:
`MENU P01: DMX ADDRESS MOTORYOKE`
-   depress ... until `MENÜ P04` is displayed.
-  depress The second line displays the currently adjusted value.
-   depress Adjust the desired value. The motoryoke moves to the indicated position.
-  depress You are back on menu level.
-  depress The equipment is ready for operation.







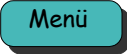

P06 TILT-axis 0-position

With this function the **TILT-axis fine adjustment** of the 0-position can be made. Please read first chapter *TILT-axis moving range*, page 15. This function can only be used for **fine** adjustment.

Range of values: 2000..2100 unit (value of the absolute value device)

Recommended value: 2048

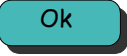
Operation:

-  depress You are now on menu level. The last adjusted menu point is displayed, e.g.:
`MENU P01: DMX ADDRESS MOTORYOKE`
-   depress ... until `MENU P06` is displayed.
-  depress The second line displays the currently adjusted value.
-   depress Adjust the desired value. The motoryoke moves to the indicated position.
-  depress You are back on menu level.
-  depress The equipment is ready for operation.

P07 Barndoor rotation middle position







With this function the **barndoor rotation middle position** can be set. Barndoor number **1** should be in horizontal (top) position.

This function is only available if the barndoor is **switched on**. This can be done in *P03, motorized barndoor ON/OFF, page 22*.

Range of values: 700..4000 unit (value of the absolute value device)

Recommended value: 2048

Operation:

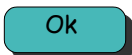
-  depress You are now on menu level. The last adjusted menu point is displayed, e.g.:
`MENU P01: DMX ADDRESS MOTORYOKE`
-   depress ... until `MENU P07` is displayed.
-  depress The second line displays the currently adjusted value.
-   depress Adjust the desired value. The motoryoke moves to the indicated position.
-  depress You are back on menu level.
-  depress The equipment is ready for operation.

P11 PAN-axis moving range







At this point the **PAN-axis moving range** can be programmed. The moving range has as reference point the PAN-axis middle position which can be set in P05, *PAN-axis middle position, page 24*. For example: If this menu is programmed to 90°, the motoryoke moves 90° to the left **and** 90° to right from middle position.

Before programming this point read chapter *PAN-axis moving range, page 13* and *P05 PAN-axis middle position, page 24!*

Range of values: 10..182 degrees

Recommended value: 90°

Operation:

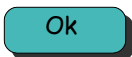
-  depress You are now on menu level. The last adjusted menu point is displayed, e.g.:
`MENU P01: DMX ADDRESS MOTORYOKE`
-   depress ... until `MENÜ P11` is displayed.
-  depress The second line displays the currently adjusted value.
-   depress Adjust the desired moving range
-  depress You are back on menu level.
-  depress The equipment is ready for operation.

Caution !!

Check the **entire moving** range of the lamp:

The lamp-manufacturer specify **minimum distances** to inflammable materials. Never fall below the minimum distance in no position of the lamp!

Make sure that no cable will be **broken, bended, stretched** or **damaged** anyhow by reason of turning the motoryoke!

P12 TILT-down (negative) moving range







At this point the **TILT-down moving range** can be set. For the TILT-axis the moving ranges (up and down) must be programmed individually. The negative moving range is defined as the „direction bottom“ range. The moving ranges have the 0-position as reference point. This point can be set in *P06, TILT-axis 0-position, page 25*.

Before programming this point read chapter *TILT-axis moving range, page 15* and *P06, TILT-axis 0-position, page 25*!

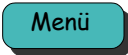
Range of values: 10..182 degrees

Recommended value: 90°

Operation:

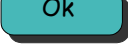
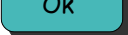
-  depress You are now on menu level. The last adjusted menu point is displayed, e.g.:
`MENU P01: DMX ADDRESS MOTORYOKE`
-   depress ... until `MENÜ P12` is displayed.
-  depress The second line displays the currently adjusted value.
-   depress Adjust the desired moving range
-  depress You are back on menu level.
-  depress The equipment is ready for operation.

Caution !!

Check the entire **moving range** of the lamp:

The lamp-manufacturer specify **minimum distances** to inflammable materials. Never fall below the minimum distance in no position of the lamp!

Check that the **motoryoke** will not be lit when lamp is on top position.

Make sure that no cable will be **broken, bended, stretched** or **damaged** anyhow by reason of turning the motoryoke!

Headlights generally must **not** be operated with the ignition electronic on the top. Observe the specifications of the lamp manufacturer!

P13 TILT-up (positive) moving range







At this point the **TILT-up moving range** can be set. For the TILT-axis the moving ranges (up and down) must be programmed individually. The positive moving range is defined as the „direction top“ range. The moving ranges have the 0-position as reference point. This point can be set in *P06, TILT-axis 0-position, page 25*.

Before programming this point read chapter *TILT-axis moving range, page 15* and *P06, TILT-axis 0-position, page 25*!

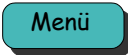
Range of values: 10..182 degrees

Recommended value: 20°

Operation:

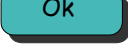
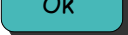
-  depress You are now on menu level. The last adjusted menu point is displayed, e.g.:
`MENU P01: DMX ADDRESS MOTORYOKE`
-   depress ... until `MENU P13` is displayed.
-  depress The second line displays the currently adjusted value.
-   depress Adjust the desired moving range
-  depress You are back on menu level.
-  depress The equipment is ready for operation.

Caution !!

Check the entire **moving range** of the lamp:

The lamp-manufacturer specify **minimum distances** to inflammable materials. Never fall below the minimum distance in no position of the lamp!

Check that the **motoryoke** will not be lit when lamp is on top position.

Make sure that no cable will be **broken, bended, stretched** or **damaged** anyhow by reason of turning the motoryoke!

Headlights generally must **not** be operated with the ignition electronic on the top. Observe the specifications of the lamp manufacturer!

P14 Focus unit 0%-value adjustment

At this point the **position of the focus unit for 0% DMX-value** can be set.

This function is only available, when focus module is switched on. This can be done in menu *P02, Focus module ON/OFF, page 21*.







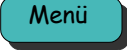

Caution!

The 0%-value must be smaller than the the 100%-value! (P14 smaller than P15)

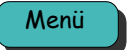
You have the possibility to set this value automatically. When depressing the menu button again (see operation), the Focus unit moves to the mechanical stop and stops moving. Now the focus unit should be moved 20 values by depressing the UP-key. This is to avoid a crash during normal moving.

Range of values: 10..4000 units (value of the absolute value device)

Operation:

-  depress You are now on menu level. The last adjusted menu point is displayed, e.g.:
`MENU P01: DMX ADDRESS MOTORYOKE`
-   depress ... until `MENÜ P14` is displayed.
-  depress The second line displays the currently adjusted value.
-   depress Adjust the desired value
or
-  depress for automatic movement to the mechanical stop.
Corrections with UP/DOWN keys are still possible.
-  depress You are back on menu level.
-  depress The equipment is ready for operation.

P15 Focus unit 100%-value adjustment

At this point the **position of the focus unit for 100% DMX-value** can be set.

This function is only available, when focus module is switched on. This can be done in menu *P02, Focus module ON/OFF, page 21*.







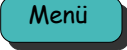

Caution!

The 100%-value must be greater than the 0%-value! (P15 greater than P14)

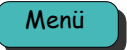
You have the possibility to set this value automatically. When depressing the menu button again (see operation), the Focus unit moves to the mechanical stop and stops moving. Now the focus unit should be moved 20 values from the stop by depressing the DOWN-key. This is to avoid a crash during normal moving.

Range of values: 10..4000 units (value of the absolute value device)

Operation:

-  depress You are now on menu level. The last adjusted menu point is displayed, e.g.:
`MENU P01: DMX ADDRESS MOTORYOKE`
-   depress ... until `MENÜ P15` is displayed.
-  depress The second line displays the currently adjusted value.
-   depress Adjust the desired value
or
-  depress for automatic movement to the mechanical stop.
Corrections with UP/DOWN keys are still possible.
-  depress You are back on menu level.
-  depress The equipment is ready for operation.

P16 Barndoor 1 closed position

At this point the **barndoor 1 position for 0% DMX-value** can be set.

This function is only available, when barndoor is switched on. This can be done in menu *P03, motorized barndoor ON/OFF, page 22.*







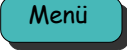

Guideline!

You should adjust the barndoors in this order: 4 3 2 1 !

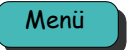
You have the possibility to set this value automatically. When depressing the menu button again (see operation), the barndoor moves to the mechanical stop and stops moving. Now the barndoor should be moved by depressing the UP-key until there is a little gap (around 1mm) between barndoor and housing/other barndoor.

Range of values: 10..4000 units (value of the absolute value device)

Operation:

-  depress You are now on menu level. The last adjusted menu point is displayed, e.g.:
`MENU P01: DMX ADDRESS MOTORYOKE`
-   depress ... until `MENÜ P16` is displayed.
-  depress The second line displays the currently adjusted value.
-   depress Adjust the desired value
or
-  depress for automatic movement to the mechanical stop.
Corrections with UP/DOWN keys are still possible.
-  depress You are back on menu level.
-  depress The equipment is ready for operation.

P18 Barndoor 2 closed position

At this point the **barndoor 2 position for 0% DMX-value** can be set.

This function is only available, when barndoor is switched on. This can be done in menu *P03, motorized barndoor ON/OFF, page 22.*







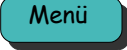

Guideline!

You should adjust the barndoors in this order: 4 3 2 1 !

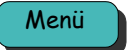
You have the possibility to set this value automatically. When depressing the menu button again (see operation), the barndoor moves to the mechanical stop and stops moving. Now the barndoor should be moved by depressing the UP-key until there is a little gap (around 1mm) between barndoor and housing/other barndoor.

Range of values: 10..4000 units (value of the absolute value device)

Operation:

-  depress You are now on menu level. The last adjusted menu point is displayed, e.g.:
`MENU P01: DMX ADDRESS MOTORYOKE`
-   depress ... until `MENÜ P18` is displayed.
-  depress The second line displays the currently adjusted value.
-   depress Adjust the desired value
or
-  depress for automatic movement to the mechanical stop.
Corrections with UP/DOWN keys are still possible.
-  depress You are back on menu level.
-  depress The equipment is ready for operation.

P20 Barndoor 3 closed position

At this point the **barndoor 3 position for 0% DMX-value** can be set.

This function is only available, when barndoor is switched on. This can be done in menu *P03, motorized barndoor ON/OFF, page 22.*







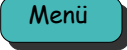

Guideline!

You should adjust the barndoors in this order: 4 3 2 1 !

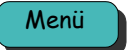
You have the possibility to set this value automatically. When depressing the menu button again (see operation), the barndoor moves to the mechanical stop and stops moving. Now the barndoor should be moved by depressing the UP-key until there is a little gap (around 1mm) between barndoor and housing/other barndoor.

Range of values: 10..4000 units (value of the absolute value device)

Operation:

-  depress You are now on menu level. The last adjusted menu point is displayed, e.g.:
`MENU P01: DMX ADDRESS MOTORYOKE`
-   depress ... until `MENÜ P20` is displayed.
-  depress The second line displays the currently adjusted value.
-   depress Adjust the desired value
or
-  depress for automatic movement to the mechanical stop.
Corrections with UP/DOWN keys are still possible.
-  depress You are back on menu level.
-  depress The equipment is ready for operation.

P22 Barndoor 4 closed position

At this point the **barndoor 3 position for 0% DMX-value** can be set.

This function is only available, when barndoor is switched on. This can be done in menu *P03, motorized barndoor ON/OFF, page 22*.







Guideline!

You should adjust the barndoors in this order: 4 3 2 1 !

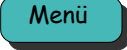
You have the possibility to set this value automatically. When depressing the menu button again (see operation), the barndoor moves to the mechanical stop and stops moving. Now the barndoor should be moved by depressing the UP-key until there is a little gap (around 1mm) between barndoor and housing/other barndoor.

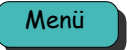
Range of values: 10..4000 units (value of the absolute value device)

Operation:

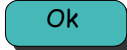
-  depress You are now on menu level. The last adjusted menu point is displayed, e.g.:
`MENU P01: DMX ADDRESS MOTORYOKE`
-   depress ... until `MENÜ P22` is displayed.
-  depress The second line displays the currently adjusted value.
-   depress Adjust the desired value
or
-  depress for automatic movement to the mechanical stop.
Corrections with UP/DOWN keys are still possible.
-  depress You are back on menu level.
-  depress The equipment is ready for operation.







P23 Barndoor 1..4 moving range

With this function the **opening angle** of all barndoors can be set. This adjustment is for all 4 barndoors.

This function is only available, when barndoor is switched on. This can be done in menu *P03, motorized barndoor ON/OFF, page 22.*

Range of values: 10..130 degrees

Operation:

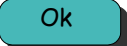
-  depress You are now on menu level. The last adjusted menu point is displayed, e.g.:
`MENU P01: DMX ADDRESS MOTORYOKE`
-   depress ... until `MENÜ P23` is displayed.
-  depress The second line displays the currently adjusted value.
-   depress Adjust the desired moving range
-  depress You are back on menu level.
-  depress The equipment is ready for operation.

P24 All barndoors closed position adjustment



With this function, you can set the closed position of the barndoors at once and automatically. It is much faster but less precise than the menus P16, P18, P20 and P22.

This function is only available, when barndoor is switched on. This can be done in menu *P03, motorized barndoor ON/OFF, page 22.*

Before using this function, please **close** all barndoors via the lighting desk. After that call menu P24 as follows!

Operation:

 depress You are now on menu level. The last adjusted menu point is displayed, e.g.:
`MENU P01: DMX ADDRESS MOTORYOKE`

  depress ... until `MENÜ P24` is displayed.

 depress The display indicates the four potentiometer values.

Press with your finger on the top barndoor 1.

Wait until the potentiometer values have been reached a constant value.

 depress The positions are saved.

 depress You are back on menu level.

 depress The equipment is ready for operation.

P25 Barndoor rotation moving range







With this function the **moving range of the barndoor rotation** can be set. The rotation angle has as reference point the middle position of the barndoor rotation, described in *P07 Barndoor rotation middle position, page 26*. If this menu is programmed to 90°, the barndoor rotation moves 90° to the left **and** 90° to right from the middle position.

This function is only available, when barndoor is switched on. This can be done in menu *P03, motorized barndoor ON/OFF, page 22*.

Range of values: 10..130 degrees

Recommended value: 90°

Operation:

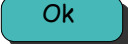
-  depress You are now on menu level. The last adjusted menu point is displayed, e.g.:
`MENU P01: DMX ADDRESS MOTORYOKE`
-   depress ... until `MENÜ P25` is displayed.
-  depress The second line displays the currently adjusted value.
-   depress Adjust the desired moving range
-  depress You are back on menu level.
-  depress The equipment is ready for operation.

P27 Speed PAN/TILT setup

At this point the number of **speed channels** can be set. The speed for PAN and TILT axis can be programmed to one channel for both axis or to two channels. One for each axis.







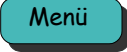

When using the Licht-Technik control panels with Joystick, this Parameter must be set to 1.

Caution!

The **order of DMX-channels** is changed with this function! Refer to *DMX-channels motoryoke, page 19*.

Range of values: 0: Speed PAN and TILT together. One DMX-channel.
1: Speed PAN and TILT separated. Two DMX-channels.

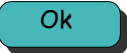
Operation:

-  depress You are now on menu level. The last adjusted menu point is displayed, e.g.:
`M E N U P 0 1 : D M X A D D R E S S M O T O R Y O K E`
-   depress ... until `M E N U P 2 7` is displayed.
-  depress The second line displays the currently adjusted value.
-   depress Adjust the desired value.
-  depress You are back on menu level.
-  depress The equipment is ready for operation.

P28 Barndoor automove function ON/OFF

In this menu the automove **function** can be switched ON or OFF.

If **2 or more** barndoors are moved (opened or closed makes no difference) at once, the control unit can calculate the right moving order to avoid crashes (if this menu is set to 1).

When closing, the barndoors are moved in this order: 4, 3, 2, 1.

When opening, the barndoors are move in the inverse order: 1, 2, 3, 4.



But: If only one barndoor is moved a crash can occur! E.g.: It will crash if all barndoors closed and only moving number 1!

This function is only available, when barndoor is switched on. This can be done in menu *P03, motorized barndoor ON/OFF, page* .



Range of values: 0: Automove function **off**
1: Automove function **on**

Operation:

-  depress You are now on menu level. The last adjusted menu point is displayed, e.g.:
`MENU P01: DMX ADDRESS MOTORYOKE`

-   depress ... until `MENÜ P28` is displayed.

-  depress The second line displays the currently adjusted value.

-   depress Adjust the desired value.

-  depress You are back on menu level.

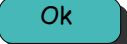
-  depress The equipment is ready for operation.



P30 Displaying the DMX-value

This function assists you in **checking** the values transmitted by the light mixer panel. At this point you can quickly detect whether the motoryoke is triggered with the **correct** values. It is possible to check all 512 DMX channels. Note that the value of the address programmed in this menu will be indicated in normal operation. After power up the programmed address in menu P01 (page 20) will be displayed.



Range of values: Address 1..512

Operation:

-  depress You are now on menu level. The last adjusted menu point is displayed, e.g.:
`MENU P01: DMX ADDRESS MOTORYOKE`

-   depress ... until `MENU P30` is displayed.

-  depress The second line displays the currently adjusted value.

-   depress Adjust the desired address.

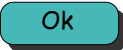
-  depress You are back on menu level.

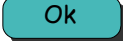
-  depress The equipment is ready for operation.



P35 Unit number Netspider

With this function you can set the **unit number** for Netspider systems.



Range of values: 0..9999

Operation:

 depress You are now on menu level. The last adjusted menu point is displayed, e.g.:
`MENU P01: DMX ADDRESS MOTORYOKE`

  depress ... until `MENU P35` is displayed.

 depress The second line displays the currently adjusted value.

  depress Adjust the desired unit number.

 depress You are back on menu level.

 depress The equipment is ready for operation.

P36 Interchanging PAN moving direction



With this function the **PAN moving direction** can be set.

Range of values: 0 = normal (standard)
1 = reverse direction

Recommended value: 0

Operation:

 depress You are now on menu level. The last adjusted menu point is displayed, e.g.:
`MENU P01: DMX ADDRESS MOTORYOKE`

  depress ... until `MENU P36` is displayed.

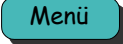
 depress The second line displays the currently adjusted value.

  depress Adjust the desired direction.

 depress You are back on menu level.

 depress The equipment is ready for operation.

P37 Interchanging TILT moving direction



With this function the **TILT moving direction** can be set.

Range of values: 0 = normal (standard)
1 = reverse direction

Recommended value: 0

Operation:

 depress You are now on menu level. The last adjusted menu point is displayed, e.g.:
`MENU P01: DMX ADDRESS MOTORYOKE`

  depress ... until `MENU P37` is displayed.

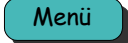
 depress The second line displays the currently adjusted value.

  depress Adjust the desired direction.

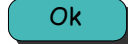
 depress You are back on menu level.

 depress The equipment is ready for operation.

P38 Interchanging Focus moving direction



With this function the **Focus moving direction** can be set.

Range of values: 0 = normal (standard)
1 = reverse direction

Recommended value: 0

Operation:

 depress You are now on menu level. The last adjusted menu point is displayed, e.g.:
`MENU P01: DMX ADDRESS MOTORYOKE`

  depress ... until `MENU P38` is displayed.

 depress The second line displays the currently adjusted value.

  depress Adjust the desired direction.

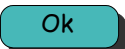
 depress You are back on menu level.

 depress The equipment is ready for operation.

P39 Interchanging barndoor rotation moving direction



With this function the **barndoor rotation moving direction** can be set.

Range of values: 0 = normal (standard)
1 = reverse direction

Recommended value: 0

Operation:

 depress You are now on menu level. The last adjusted menu point is displayed, e.g.:
`MENU P01: DMX ADDRESS MOTOR YOKE`

  depress ... until `MENU P39` is displayed.

 depress The second line displays the currently adjusted value.

  depress Adjust the desired direction.

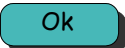
 depress You are back on menu level.

 depress The equipment is ready for operation.

Technical data

Weights and dimensions:

The identification number is described on page 5.

MB-ST/B	Width [cm]	Height [cm]	Depth [cm]	Weight [kg]	max. load [kg]
008	70	58	16	10.5	55
013	73	67	16	13.5	55
014	63	55	16	10.5	55

MB-R	Width [cm]	Height [cm]	Depth [cm]	Weight [kg]	max. load [kg]
002	53.8	47,8	21	11.6	55
006	68.8	57,8	21	12,0	55
008	56,0	57,8	21	11,7	55
010	74,8	65,8	21	12,0	55
011	60,8	53,8	21	11,7	55

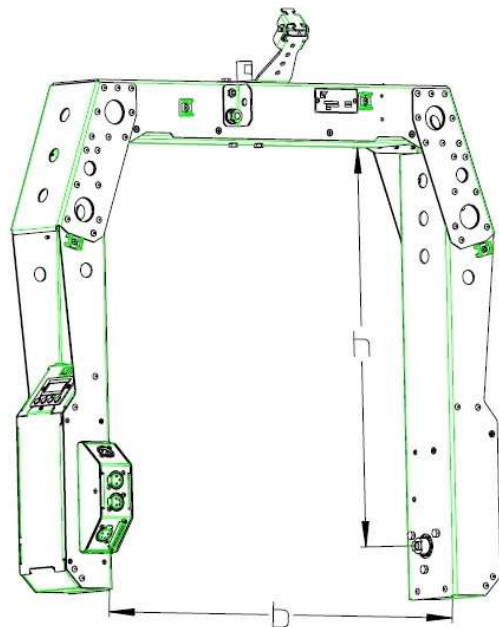

MB-ST/B xxx	b	h
MB-ST/B 008	536	436
MB-ST/B 013	566	530
MB-ST/B 014	466	406

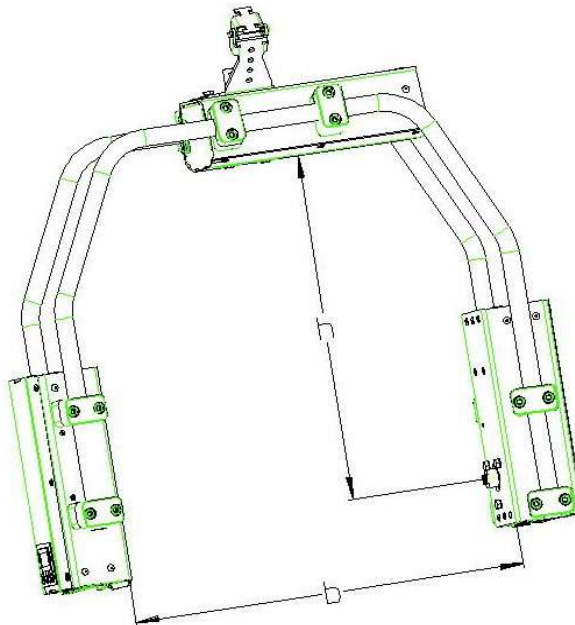

MB-R xxx	b	h
MB-R 002	378	342
MB-R 006	528	442
MB-R 008	400	442
MB-R 010	588	522
MB-R 011	448	402

Connected loads: 24 V DC, max. 5 A

Fuse: 6.3 A slow blow

Pin assignment:

Data-Power-cable: 4pin XLR connector screened

Housing: Screen

PIN 1: 0 V (GND) min. cross section 0,75mm²

PIN 2: DMX-Data – min. cross section 0,25mm²

PIN 3: DMX-Data + min. cross section 0,25mm²

PIN 4: +24 V DC min. cross section 0,75mm²

The DMX wires must be twisted pair and shielded separately.

Focuscable: 5pin XLR connector min. cross section: 0,25 mm² screened.

PIN 1: Motor -

PIN 2: Motor +

PIN 3: Potentiometer 1

PIN 4: Potentiometer 2

PIN 5: Potentiometer 3

Screen connected to housing of XLR-connector

DMX power switching: 3pin XLR connector min. cross section 0,25 mm² screened

PIN 1: GND

PIN 2: Filament 1

PIN 3: Filament 2

Screen connected to housing of XLR-connector

Barndoor cable:

Pin number	Signal	Pin number	Signal
Pin 1	Motor barndoor rot -	Pin 13	Not connected
Pin 2	Motor barndoor 4 -	Pin 14	Motor barndoor rot +
Pin 3	Motor barndoor 3 -	Pin 15	Motor barndoor 4 +
Pin 4	Motor barndoor 2 -	Pin 16	Motor barndoor 3 +
Pin 5	Motor barndoor 1 -	Pin 17	Motor barndoor 2 +
Pin 6	GND (ground)	Pin 18	Motor barndoor 1 +
Pin 7	Potentiometer barndoor 2	Pin 19	Potentiometer barndoor 1
Pin 8	Not connected	Pin 20	Potentiometer GND
Pin 9	Potentiometer barndoor 3	Pin 21	Potentiometer barndoor 4
Pin 10	Potentiometer Vcc (+5V)	Pin 22	Potentiometer barndoor rot
Pin 11	Not connected	Pin 23	GND
Pin 12	Not connected	Pin 24	Not connected
		Pin 25	Not connected

Readjustment of motoryoke axis

Caution!

Only for **Licht-Technik trained personal!**

These works can only be done in a **well equipped workshop**. It is absolutely **forbidden** to do these works on **ladders** or **lifts!**

If a potentiometer has to be changed or disassembled, an adjustment of the potentiometer is necessary, please follow these instructions:

Readjustment PAN-axis:

1. Move the **powered off** motoryoke onto **middle** position of the PAN-moving range.
2. Put the Potentiometer onto the **half** printed resistor value. Check it with an Ohmmeter.
3. **Install** the Potentiometer.
4. Set the DMX-value for PAN-axis to **50%**.
5. Switch on the motoryoke **without DMX-Signal** (disconnect DMX-IN cable at power-supply/splitbox). Thus the motoryoke remains on its momentary position.
6. Set the **middle** position for PAN-axis(*P05, PAN-axis middle position, page 24*) to 2048. (default value).
7. Connect the **DMX-signal** again.
8. The motoryoke moves to **50%** DMX-position. Now the adjustment of the PAN-axis middle position can be set. (*PAN – axis moving range, page 13*).
9. Maybe the moving range **angle** must be readjusted. Refer to *PAN – axis moving range, page 13* and *P11 PAN-axis moving range, page 27*.
10. Check the both **end-positions** via the light mixing panel.

Readjustment TILT-axis:

1. Move the **powered off** motoryoke onto **middle** position of the TILT-axis moving range (at default-value about 45 degrees to bottom).
2. Put the Potentiometer onto the **half** printed resistor value. Check it with an Ohmmeter.
3. **Install** the Potentiometer.
4. Set the DMX-value for TILT-axis to **50%**.
5. Switch on the motoryoke **without DMX-Signal** (disconnect DMX-IN cable at power-supply/splitbox). Thus the motoryoke remains on its momentary position.
6. Set the **middle** position for PAN-axis(*P05, PAN-axis middle position, page 24*) to 2048. (default value).
7. Connect the **DMX-signal** again.
8. The motoryoke moves to **50%** DMX-position. Now the adjustment of the TILT-axis middle position can be set. Use menu *P06 TILT-axis 0-position, page 25* and *TILT – axis moving range, page 15*.
9. Maybe the moving range **angle** must be readjusted. Refer to *TILT – axis moving range, page 15* and *P12 TILT - down moving range, page 28* and *P13 TILT- up moving range, page 29*.
10. Check the both **end-positions** via the light mixing panel.

Readjustment Focus-axis:

1. **Disconnect** the 5pin XLR-cable from the motoryoke to the focus unit.
2. Move the Focus of the Headlight onto middle position of the moving range. If no knobs for manual moving are installed, the focus motor must be driven by a 12-20V DC power supply. The focus unit must not be connected to the control unit!! (disconnect 5pin cable to the yoke).
3. Put the Potentiometer onto the **half** printed resistor value. Check it with an Ohmmeter. You can do that on the installed potentiometer by turning the toothed wheel. You have to lift it a little bit to disconnect the mechanical toothwheel connection.
4. Switch on the motoryoke **without DMX-Signal** (disconnect DMX-IN cable at power-supply/splitbox). Thus the motoryoke remains on its momentary position.
5. Set the two endpositions with *P14, Focus unit 0%-value adjustment, page 30* and *P15 Focus unit 100%-value adjustment, page 31*.
6. Connect the **DMX-signal** again.
7. Check the both **end-positions** via the light mixing panel.

Factory presettings

Menu	Description	Value
P01	DMX-address motoryoke	1
P02	Fokus module ON/OFF	0/1 (individual)
P03	Motorized barndoor ON/OFF	0/1 (individual)
P04	DMX-address power switching	individual
P05	PAN-axis middle position	individual
P06	TILT-axis 0-position	individual
P07	Barndoor rotation middle position	individual
P11	PAN-axis moving range	160 degree
P12	TILT-down (negative) moving range	90 degree
P13	TILT-up (positive) moving range	20 degree
P14	Focus unit 0% value adjustment	individual
P15	Focus uinit 100% value adjustment	individual
P16	Barndoor 1 closed position	individual
P18	Barndoor 2 closed position	individual
P20	Barndoor 3 closed position	individual
P22	Barndoor 4 closed position	individual
P23	Barndoor 1..4 moving range	120 degree
P25	Barndoor rotation moving range	90 degree
P27	Speed PAN/TILT setup	0 (1 channel)
P28	Barndoor autoclose function ON/OFF	1 (ON)
P30	Displaying DMX-value	1
P32	Selecting the user language	1 (englisch)
P35	Unit number Netspider	0
P36	Interchanging PAN-moving direction	0
P37	Interchanging TILT-moving direction	0
P38	Interchanging Focus-moving direction	0
P39	Interchanging barndoor rotation PAN-moving direction	0

Maintenance

By regular maintenance a significant increase of **lifetime** and **reliability** can be achieved.

Regular maintenance increases safety significant!!

We recommend a maintenance once a year.

Obligatory are the following points:

1. Checking the fixing parts:

The fastening spigot must be **checked visual**. The spigot must be in right angel to the housing. This must be checked in **front** and **side** view. A **protractor** can be a help.

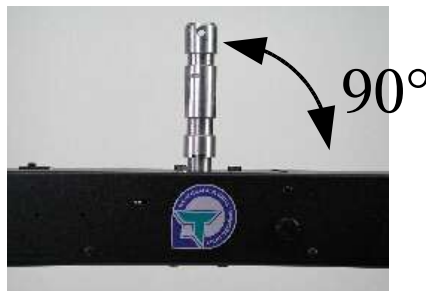

Furthermore, the **spigot** itself and the **surface** of the yoke must not be deformed. Make sure that the spigot is not loose.

If the spigot is visibly **damaged** or deformed the motoryoke must not be used anymore. The device has to be sent to Licht-Technik.

2. Checking the safety elements

Check the safetybelts and further safetyelements like shackles, rings, lugs, chains:

- Are the belts not frayed out?
- Are the threads of the shackles okay? Are the screws easy to turn?
- Are there no visible damages at the safety elements?
- Do the belts not rasp on other parts?

3. Checking the cables and supply lines

- Check the cables visibly for damages.
- Check the entire moving range of PAN and TILT, if the cables are not **broken, bended, stretched** or **damaged** anyhow.
- Are the cables not porous?

4. Checking the screw connections of the lamp fixings

- Check all clamping bolts if they are well fixed.

Following maintenance is **recommended**:

- Remove dust, especially on electrical parts. Electronic is very sensitive for dust and reacts with strange behaviour!
- Keep focus spindle inside the lamp turnable with *Loctite 8151*™.
- Fatten the potentiometer-toothwheel with temperature stable bearing fat.
Recommended: Use a brush to put the fat on it. Do not use too much. A few grams are enough.

Error messages

Only Licht-Technik trained personal is authorised to work on the motoryoke!

Error	Description	Possible reasons	Possible solutions
E20	DMX-Signal missing	Defective supply line (data power) to the motoryoke. (Pin2 and/or 3 broken) Defective supply line to the splitbox (Pin2 and/or 3 broken)	Check the DMX-signal cables. The LED „DMX ok“ at the splitbox must light DMX mixing panel not ready
E21	DMX-Signal interchanged	Defective supply line (data power) to the motoryoke. (Pin2 and/or 3 interchanged) Defective supply line to the splitbox (Pin2 and/or 3 interchanged)	Check the DMX-signal cables. The LED „DMX ok“ at the splitbox must light.
E23	DMX-noise	Too much cable length. Bad signal quality.	Check the DMX signal cables. Check the DMX-connections Use a terminating resistor
E28	EEPROM error. Program memory test failed	Aging Electrostatic charge	No solutions. Inform Licht-Technik
E29	RAM Error. Working memory test failed	Aging Electrostatic charge	No solutions. Inform Licht-Technik
E30	PAN-motor blocked	Cable to motor broken	Check connections/solder joints
E31	TILT-motor blocked	Cable to potentiometer broken	Check connections/solder joints
		Potentiometer defective	Change potentiometer
		Motor defective	Change motor
		Yoke is blocked mechanically	Remove blocking
		A foreign object is in/at the drive	Remove object
		Motor/potentiometer connections interchanged when replaced.	Check connections
			Inform Licht-Technik
E32	Focus Motor blocked	Focus axis blocked	Check easy movement of the axis. Put some fat on axis (Loctite™ 8151)
		Moving range in P14, P15 not correct	Set correct values
		Focus motor defective	Change motor
		Focus potentiometer defective	Change potentiometer
		Connection cable to Focus module defective	Check connections and possible short circuits
			Inform Licht-Technik
E33	Barndoor 1blocked	Barndoor mechanically blocked	Remove blocking
E34	Barndoor 2blocked	Axis blocked	Check easy movement of the axis.
E35	Barndoor 3blocked		
E36	Barndoor 4blocked	Moving range in P16 - P23 not correct	Set correct values
		Barndoor motor defective	Change motor
		Barndoor potentiometer defective	Change potentiometer
		Connection cable to barndoor module defective	Check connections and possible short circuits
			Inform Licht-Technik
Barndoor rotation			
E37	blocked	Barndoor rotation mechanically blocked	Remove blocking
		Moving range in P07 - P25 not correct	Set correct values
		Barndoor rotation motor defective	Change motor
		Barndoor rotation potentiometer defective	Change potentiometer
		Connection cable to barndoor module defective	Check connections and possible short circuits

Malfuctions

- No display after power up.

The device houses a slow-blow fuse for feeble currents of 6.30 A protecting the equipment of wrong polarities on the supply line. When the fuse is blown, cable and polarity have absolutely be checked (pin1 = 0 V, pin 4 = +24V).

- No error message but motoryoke does not move

- Check DMX-addressing (*P01, DMX-Address motoryoke, page 20*).
- Is the speed-channel not set to 0? Check it with the DMX-tester in P30, page 41

- No error message but the Focus module does not move

- Is the focus-module switched on? Check *P02, Focus module ON/OFF, page 21*.
- Is the focus-cable well connected?
- Check the incoming DMX-values with the DMX-tester in *P30, page 41*. The focus-channel is start-channel (*P01, page 20*) + 4 or 5 (depends on *P27, page 39*). Refer to *DMX-channels motoryoke, page 19*.

- No error message but the barndoor does not move

- Is the barndoor-module switched on? Check *P03, Barndoor module ON/OFF, page 22*
- Is the barndoor-cable well connected?
- Check the incoming DMX-values with the DMX-tester in *P30, page 41*. The DMX-channels for the barndoor can be checked with *DMX-channels motoryoke, page 19*.

Warranty

The warranty for our products is 2 years. It comprises any repair of failures – free of charge – which can be proved to result from defects of fabrication.

Warranty expires when:

- the device was modified or attempted to be repaired
- damages were caused by the intervention of foreign persons
- damages are due to non-compliance with the operating instructions
- the device was connected to an incorrect voltage or incorrect type of current
- the device was incorrectly operated or when damages were caused by negligent handling or misuse

All maintenance and servicing works related to the product must be carried out by the company *Licht-Technik*. *Licht-Technik* shall not assume any liability for losses or damages of any kind being the results of inexpert servicing.

Further information

This document and the information contained therein are subject to copyright and neither the whole nor any part of it may, and this is also valid for the described product, be reproduced, copied or recorded in any form without the prior written authorization of *Licht-Technik Vertriebs GmbH*.

The products of *Licht-Technik GmbH* are subject to constant development. Therefore *Licht-Technik* reserves the right to modify components, motors and also technical specifications any time and without prior notice.

Declaration of conformity

Manufacturer: Licht-Technik Vertriebs GmbH
Address: Osterwaldstraße 9-10
80805 München

declares that the product:

Name of product: Motoryoke studio 2000, Motoryoke Tube
Type of product: MB-STA, MB-STB, MB-STC, MB-R

corresponds to the following specifications under strict observance of the installation instructions and technical specifications:

**Standard 2004/108/EG of the European Parliament and the council from
15. December 2004
for law provision adaptation of the member states concerning the electrical
compatibility and for
abrogation of standard 89/336/EWG.**

The device passed the test. A testreport is available at company Licht-Technik Vertriebs GmbH.

Munich, 19.9.2005

Uwe Hagenbach / Bernhard Grill
Managing directors